

Introduction to our Concepts and Products

Am Kleinbahnhof 18-30 – 25746 Heide (DE)

www.nnc-lin.com
info@nnc-lin.com – +49(0)481 81787763



Our cooling Concept

**COOLING WITH LN₂
SIMPLE BUT EFFECTIVE**

Am Kleinbahnhof 18-30 – 25746 Heide (DE)

www.nnc-lin.com
info@nnc-lin.com – +49(0)481 81787763



Our possibilities, examples

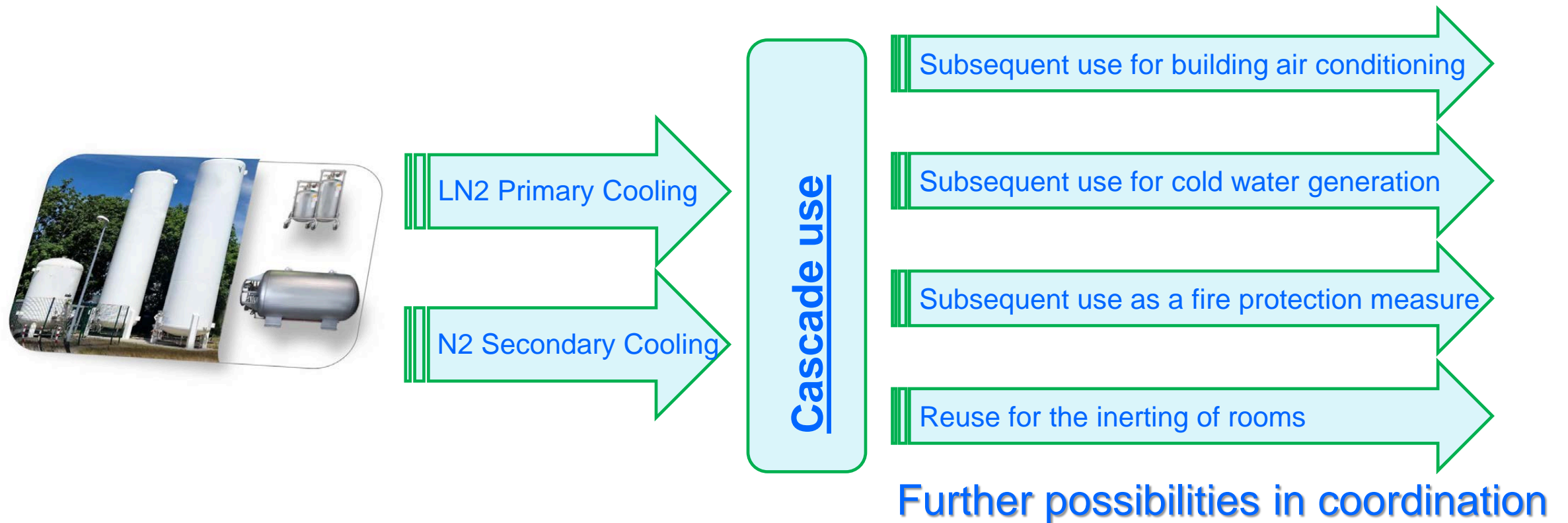

COOLING WITH LN2 / N2
SIMPLE / EFFECTIVE / SAFE

Am Kleinbahnhof 18-30 – 25746 Heide (DE)

www.nnc-lin.com
info@nnc-lin.com – +49(0)481 81787763

All our Cooling concepts follow the same principles and contain these basic components

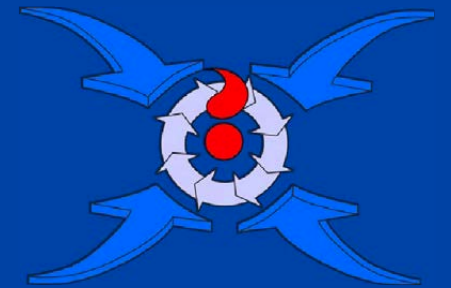

1. High performance Insulation
2. Heat Exchangers
3. Valves
4. „Cryo Supply-Box“
5. Temperature Sensors
6. Control unit
7. stainless steel pipes
8. „Thermoblock“
9. Gas Tank containing Liquid nitrogen (LN₂)

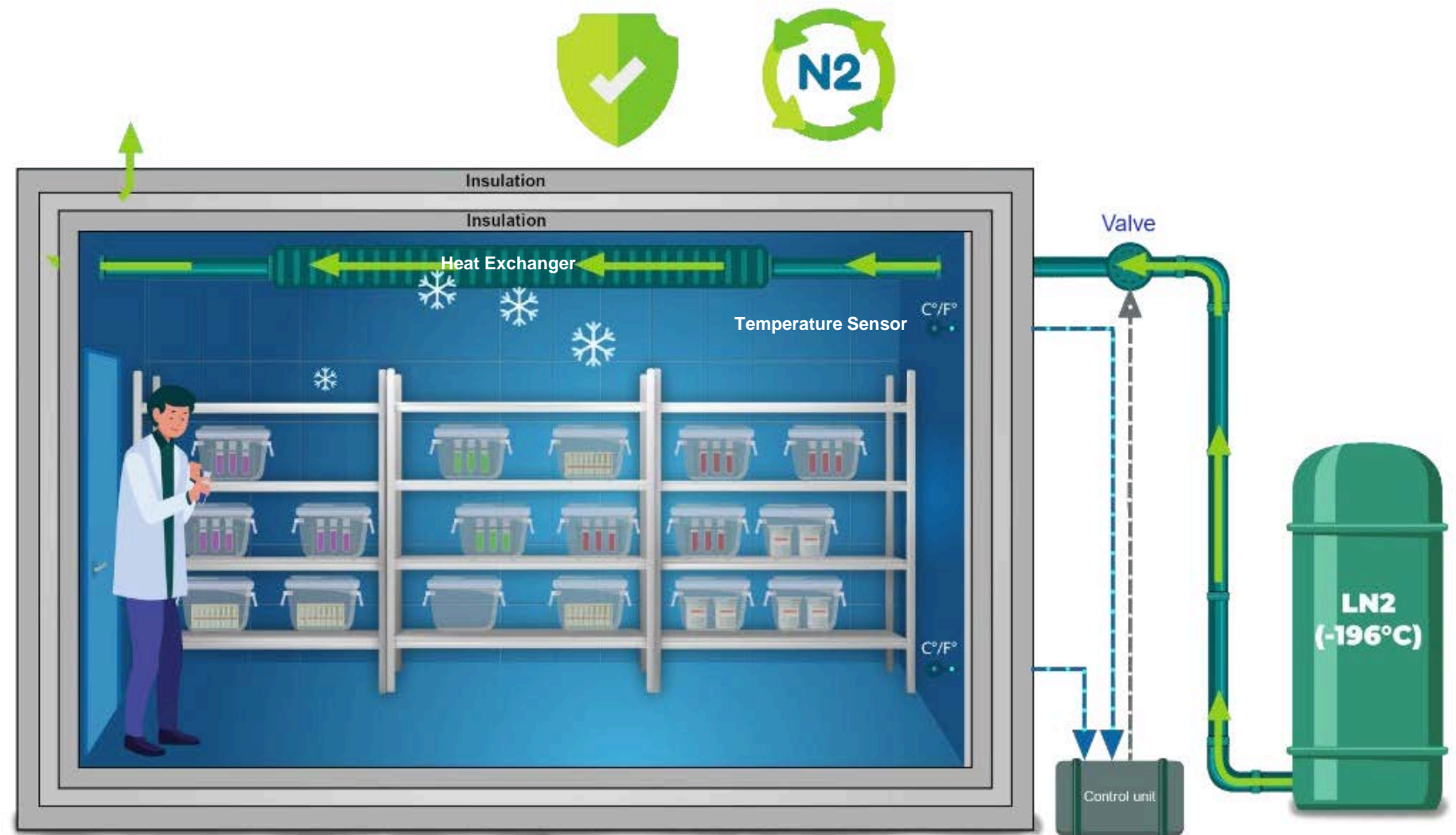

1. High performace Insulation

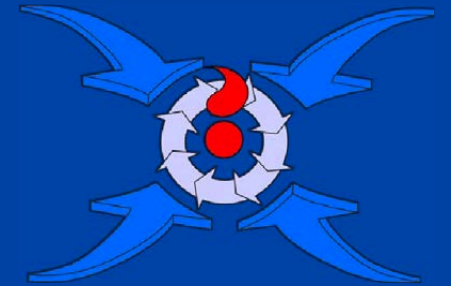

The base for all cold storage is a good insulation. Our systems have multiple layers. This saves energy and protects the insulation from intense stress caused by temperature differences.

The LN2 Consumption depends on room size (10m² to 500m² and more), as well as the temperature and other factors.

This can mean a range of 20 kg -1.000kg and more per day

Consumption can be greatly reduced by systematic NNC cascade use for other applications

The Price for LN2 depends on the supplier and the amount purchased. At least 12 to 15 cents / kg



2. Heat Exchanger

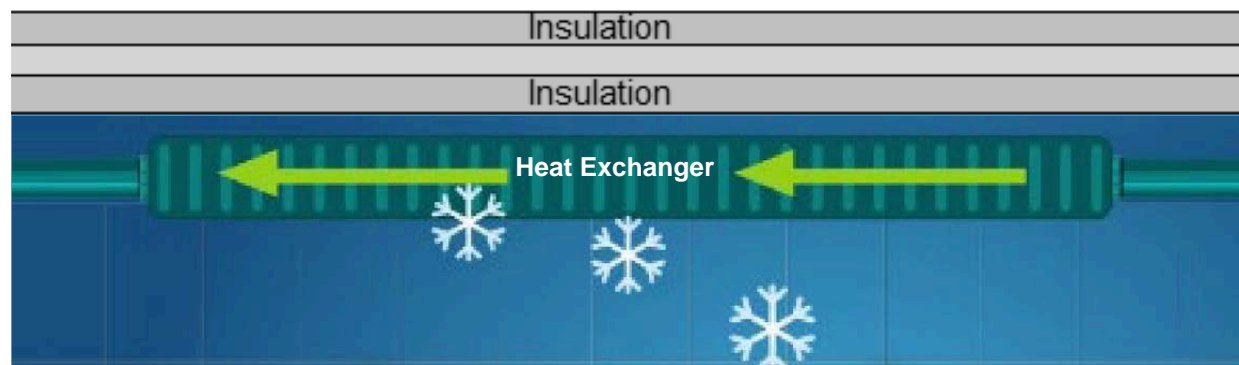
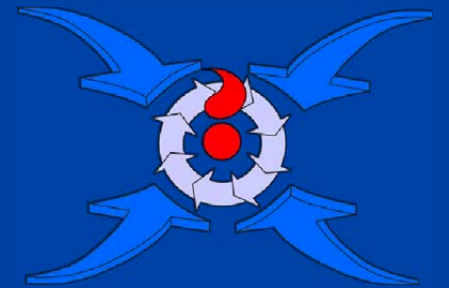

Cooling in all our systems is handled by our Heat Exchangers. These are strategically placed at the ceiling and are getting injected with liquid nitrogen which has a temperature of -196° . The warm air passes the surface of the Heat Exchanger and is getting cooled rapidly.

Warm air rising and cold air falling is creating its own thermal convection without any electric fans. This way the temperature gets into every corner.

The Liquid Nitrogen passes through the Heat exchanger and is being expelled into pipes that pass it on to another system or the outside.



3. Valves

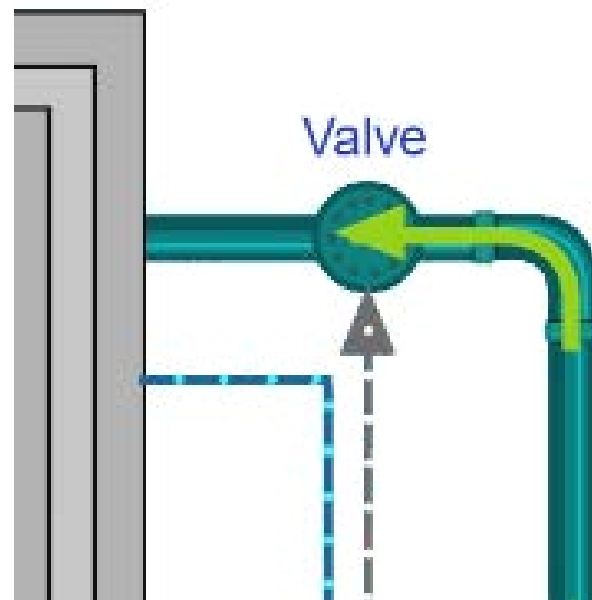
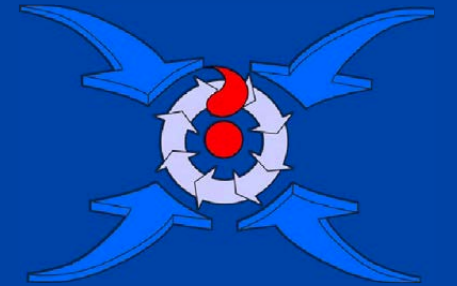

To inject the Liquid nitrogen into the Heat exchangers we use specific valves that are specially suited for this temperature range.

4. „Cryo Supply-Box“

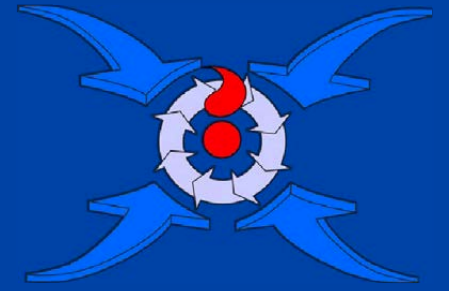

Our Valves are typically housed in an insulated housing. This prevents excessive Moisture and subsequent ice Build-up on the pipes and valves

5. Temperature Sensors

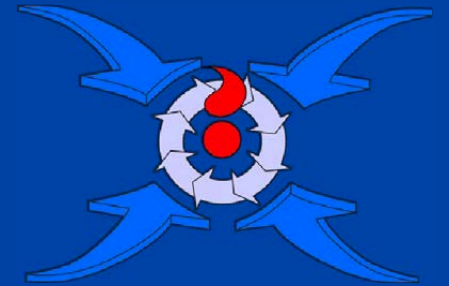

Sensors are methodically placed at multiple spots inside the storage area to monitor the temperature and give the impulse for the valves to release liquid nitrogen into the Heat Exchangers.

We typically use pt100 / pt1000 sensors that are 3-Point calibrated and meet all demands for certification and quality control like GMP.

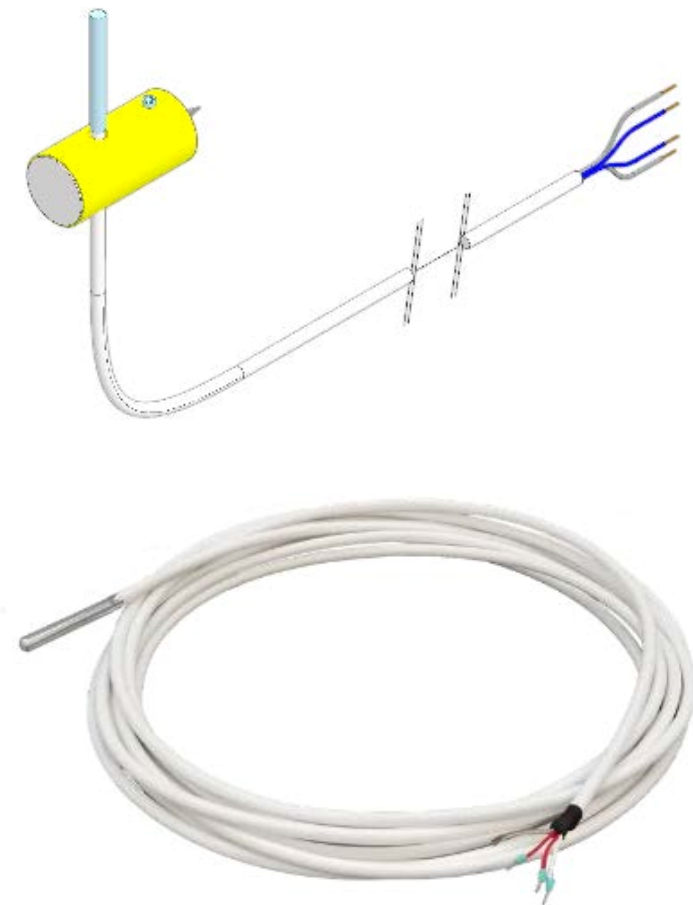

6. Control unit

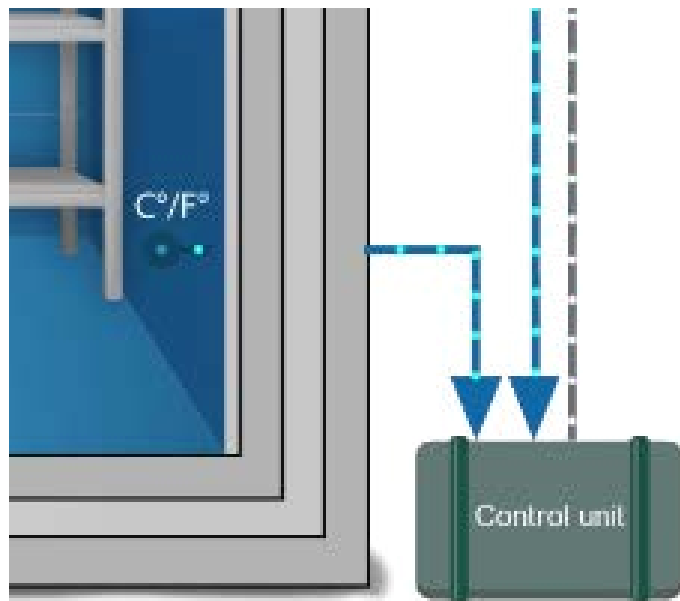
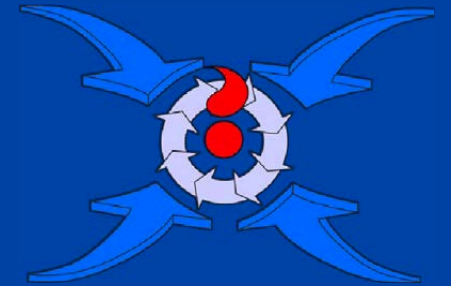

Every aspect in our systems is monitored and controlled by the control unit. The capabilities and size vary depending on the requirements. For small standalone systems, a small to medium size control panel with integrated user interface may be enough. For our open plan rooms with multiple sections a bigger unit is required.



7. Stainless steel pipes and fittings

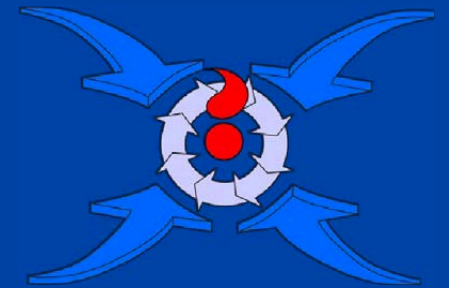

For the majority of the way to the system, vacuum insulated pipes are used. These are specially designed to transport liquid gases with very cold temperatures.

Inside the System uninsulated stainless steel pipes are used and connected via high performance fittings that can withstand pressures of up to 300 bars. This is one aspect that pushes the likelihood of a leak to near zero.



8. „Thermoblock“

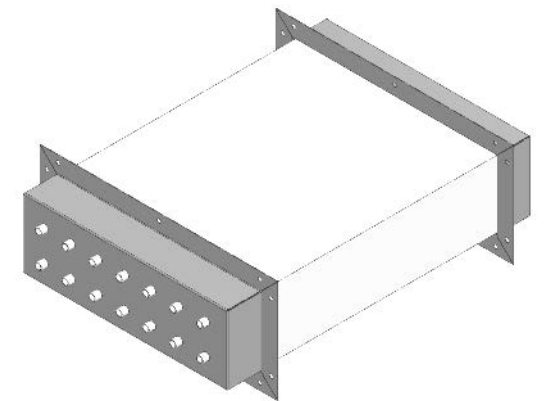
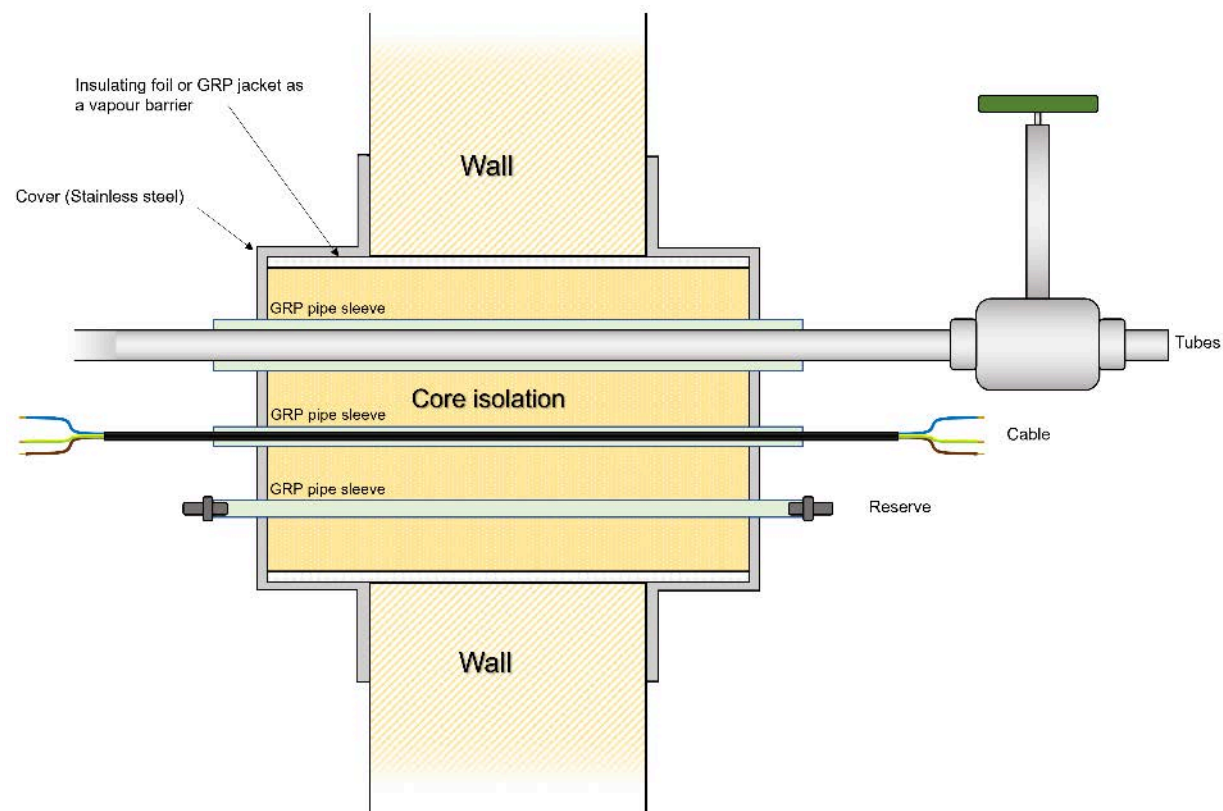
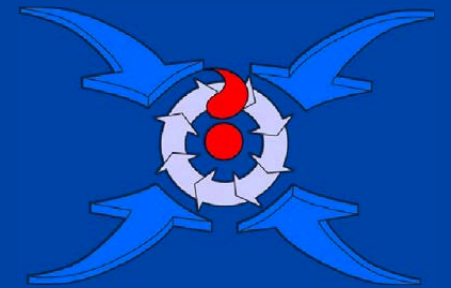

Whenever we need to run pipes or cables through an insulated wall, we use our Thermoblock. It shields the insulation from the temperatures and possible condensation emanating from pipes or cables running through the wall.

9. Gas Tank containing Liquid nitrogen (LN₂)

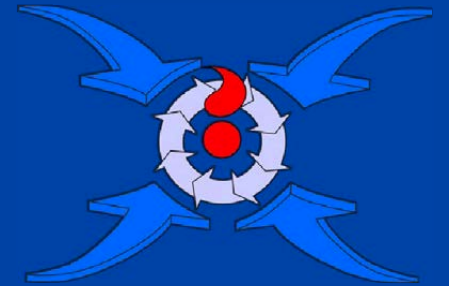

Depending on the application the needed amount of LN₂ and size of the gas tank may vary. For less demanding, standalone Systems a small movable tank-system can be sufficient. For bigger Multiroom applications a stationary tank is needed.

These tank-systems are well insulated and equipped to supply a steady stream of liquid nitrogen



Overview of key features & specifications

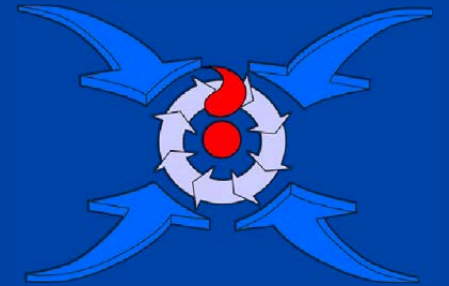

- **NNC-Cooling system, working with LN₂ (approx. -196.3°C)**
- **High performance piping in a closed system, open at the end, with cascade options**
 - ✓ **No nitrogen in the room surrounding the system**
 - ✓ **No nitrogen in the systems storage room**
 - ✓ **low 2.5 to 3 bar line pressure**
- **Customized safety and redundancy system based on your requirements**
 - ✓ **Multi-way supply, ring line**
 - ✓ **2 gas tanks**
 - ✓ **Redundant supply valves for every section**
- **UPS-backup for the control and mission critical systems**
- **Full monitoring system**
- **Connection to in-house network and monitoring components, GL**
- **and much more, as agreed with the customer**
- **.....**

NNC system comparisons >> to conventional compressor systems

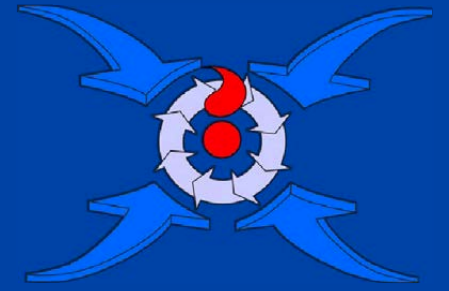

Failure possibilities in NNC systems >> prevention / Downtime:

1. Main tank empty or defective >> Redundant Tank-system for protection / no failure
2. Supply line defective >> Ring line for supply / no failure
3. Power outage >> Power outage >> Backup with 1KW UPS / no outage
4. Control failure >> have a replacement control unit on standby / maximum 1 hour
5. Component defective >> have Replacement for common parts on standby / maximum 1-2 hours

Failure possibilities in conventional Compressor systems >> prevention / Downtime:

1. Compressor defective >> drain refrigerant, replace compressor, charge refrigerant / ?? hours
2. Refrigerant leak >> drain refrigerant, check/replace lines, fill refrigerant / ?? hours
3. Motor, drive defective >> Motor replacement / up to one day if component on site
4. Power failure >> 1 hour to several days
5. Control failure >> Analyze / replace replacement control parts, ?? hours
6. Components defective >> all technical components can be damaged as they are subject to wear and tear
7. Air conditioning overloaded >> Very high technical effort
8. Overheating of rooms due to waste heat
9. Many technical components that can fail
- 10.....

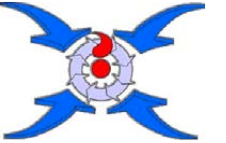

Security Concerns

SAFETY AND BACKUP

Am Kleinbahnhof 18-30 – 25746 Heide (DE)

www.nnc-lin.com
info@nnc-lin.com – +49(0)481 81787763

Frequent Questions and Concerns

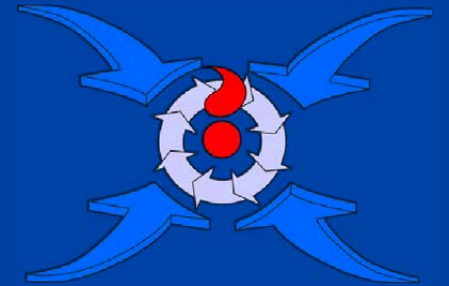

What happens if there is a LN₂ leak in the storage area, what happens to the stored products?

We can assure you that it is virtually impossible to experience leaks after acceptance/testing in the storage area.

1. the system is pressure tested before delivery
2. all materials (Pipes, fittings, components, cooling plates) are tested to at least 30 Bar/ 430PSI.

However, we can also provide additional measures in the event of increased safety requirements, spare room, stand-by devices and much more, even if it does not seem necessary to us.

Our systems and installations are always demonstrably safer than all technical refrigeration systems, as the temperature does not have to be generated on site but must be conducted in the needed manner.

What measures are planned if there is a leak in the storage room and people need to be protected?

In principle, we rule out the possibility of a leak because we do everything necessary in advance.

But the rooms are monitored for oxygen and a pneumatic valve can be fitted to the tank, which closes if too much LN₂ is being drawn.

It should also be noted that we do not have any open nitrogen outside the system, as is the case with all other systems available on the market.

These systems vent into the room, our systems vent outside into the environment.

In addition to the monitoring system, indicator lights and signaling devices are installed. This indicates danger.

Further safeguards can be agreed with the customer if required.



We would also like to point out that nitrogen is 78% of the air we breathe and is therefore CO₂ neutral and very suitable as a refrigerant.

What happens if the tank stops releasing nitrogen despite all precautions? Is there a back-up?

Yes, the pharmaceutical industry prefers 2 tanks instead of one. The systems run redundantly and back each other up. The automatic supply system ensures that refueling takes place when the filling level reaches 40%.

Is there a back-up supply line?

A single line is very safe and usually needs no redundancy, but...

1. An option is a ring line (circular) that can supply the systems in case one direction is blocked somehow
2. Of course, another possibility is a complete second line

We are happy to answer any questions you may have. We are confident enough to say that our systems are safer and more sustainable than all other systems for high-end applications.



A deeper insight

A CLOSER LOOK AT OUR
CONCEPTS AND SYSTEMS

Am Kleinbahnhof 18-30 – 25746 Heide (DE)

www.nnc-lin.com
info@nnc-lin.com – +49(0)481 81787763

BOS Open-plan

Single or multi-room storage down to -80°C

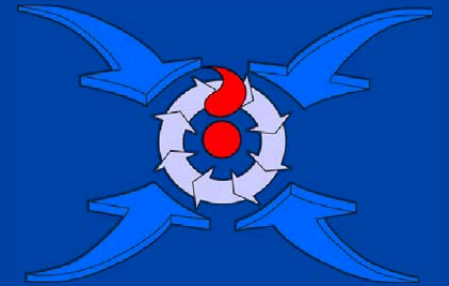

Our open-plan systems are planned from the ground up with the customer, for the customer, and can be adapted to all needs



Anteroom -20°C passively cooled by cooling of the adjacent rooms and supported by active cooling.



Storage room -75°C actively cooled by our heat exchanger plates. The remaining energy is used in other areas.

BOS Open-plan

Single or multi-room storage down to -80°C

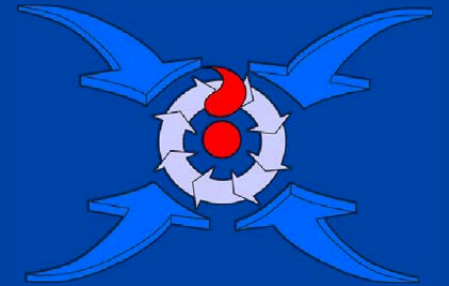

Interim storage 2-5°C passively cooled by cooling of the adjacent rooms and supported by active cooling.



Defrosting room 15-35°C actively heated by air conditioner under the ceiling.

BOS Open-plan

Single or multi-room storage down to -80°C

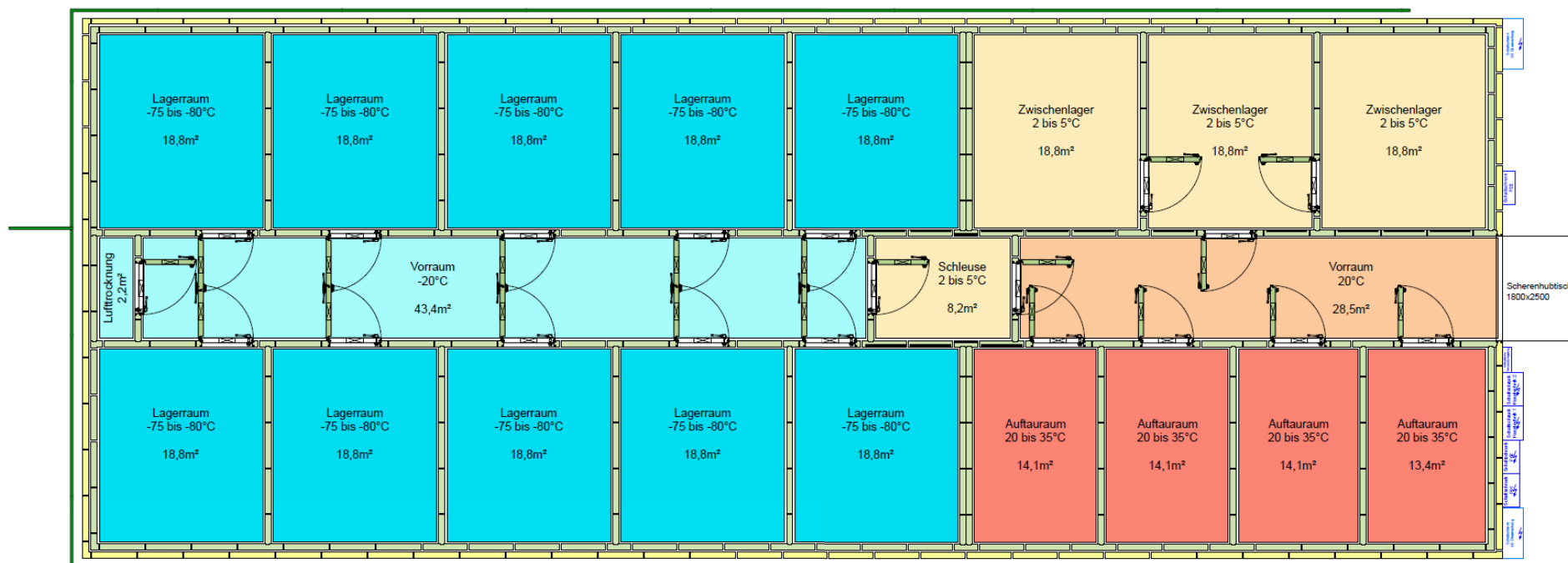
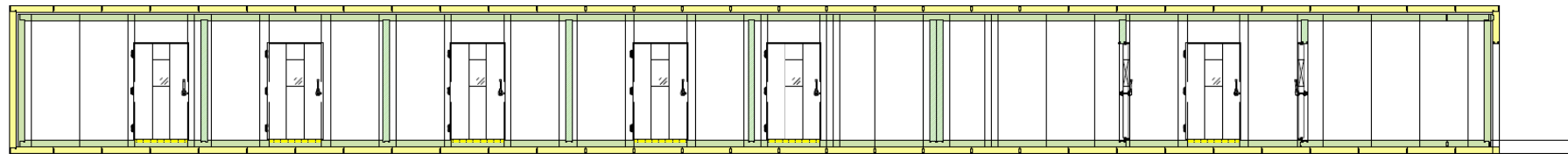
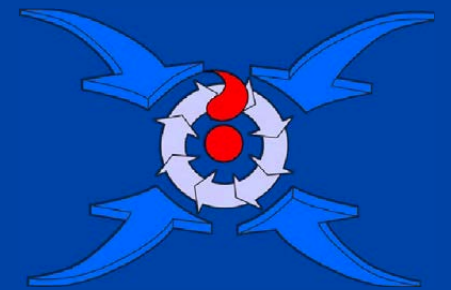

The installation costs vary greatly. Minimum costs for planning and installation can range from €1.000 to €1,000,000 and more, depending on the materials used and the location.

BOS BOS MS - Multifunctional-System

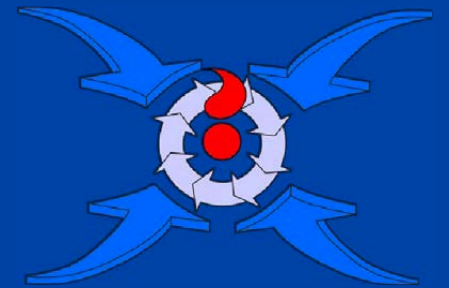

The BOS MS takes the advantages of regular cabinet systems and houses them in one multifunctional System. Each section can be fitted with a different type of storage insert (drawers, shelves, ...) at variable temperatures, that can be swapped if needed.

This system, as most BOS Products, can run in a cascade and in doing so can power sections which are set to warmer temperatures with the excess energy from the more demanding ones.

Each system is equipped with a display and managing system that can be placed exactly at the cabinet you need by locking in at different points near the door of that section.

The empty volume of each section is at about 1.000 litres. Depending on the chosen Storage insert this offers a usable space of about 800 litres.

BOS BOS MS - Multifunctional-System

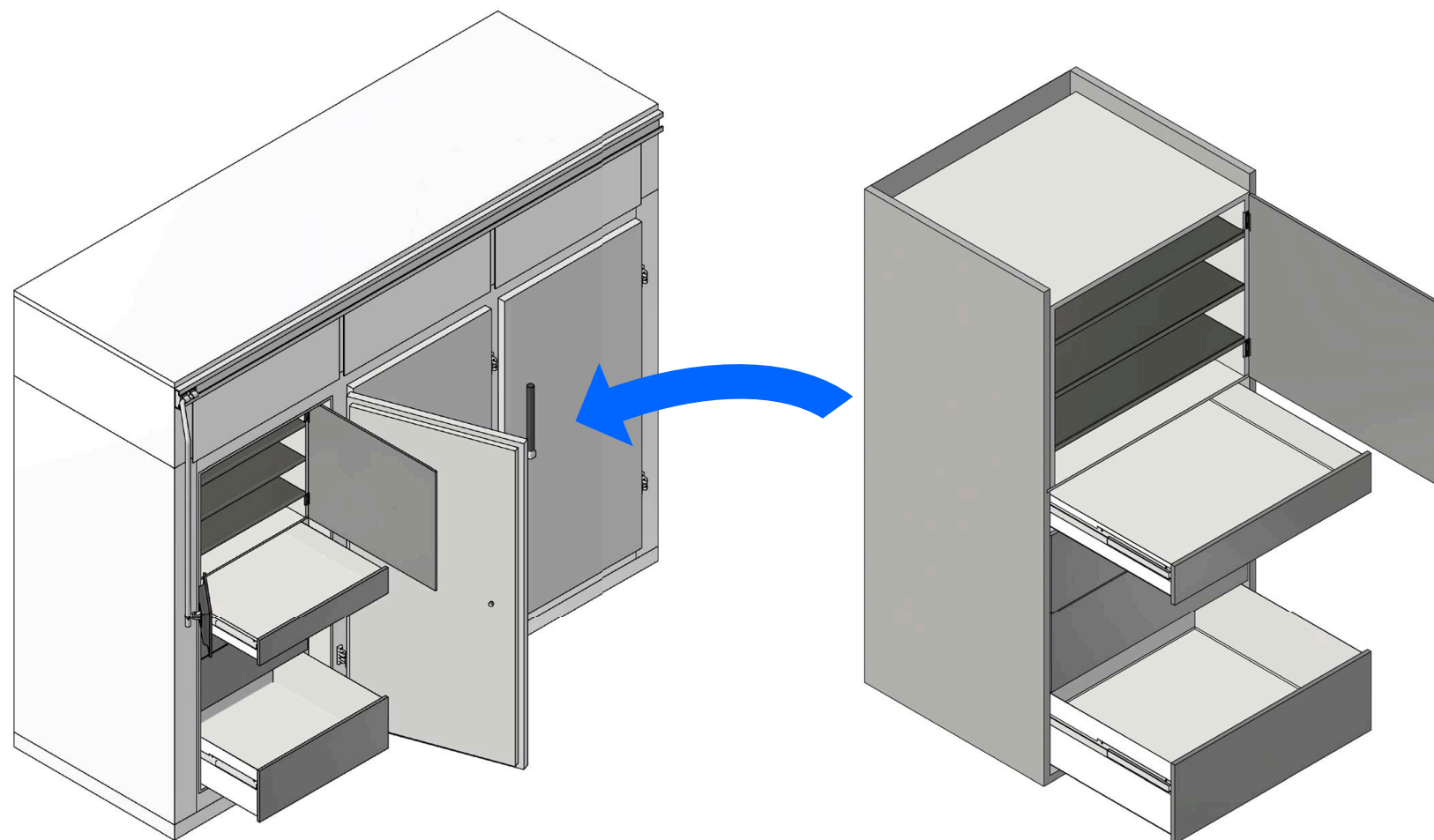
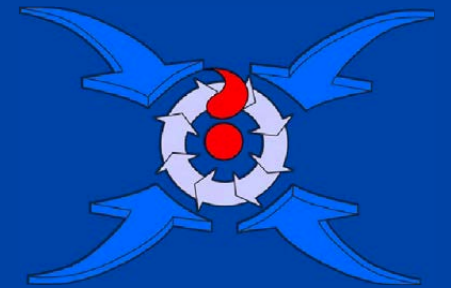

The standard Insert model comes with some drawers at the bottom. Here you can store products that need less organising.

Because drawers are only convenient until a certain height there are shelves at the top. This section can be closed separately with a door.

BOS BOS MS - Multifunctional-System

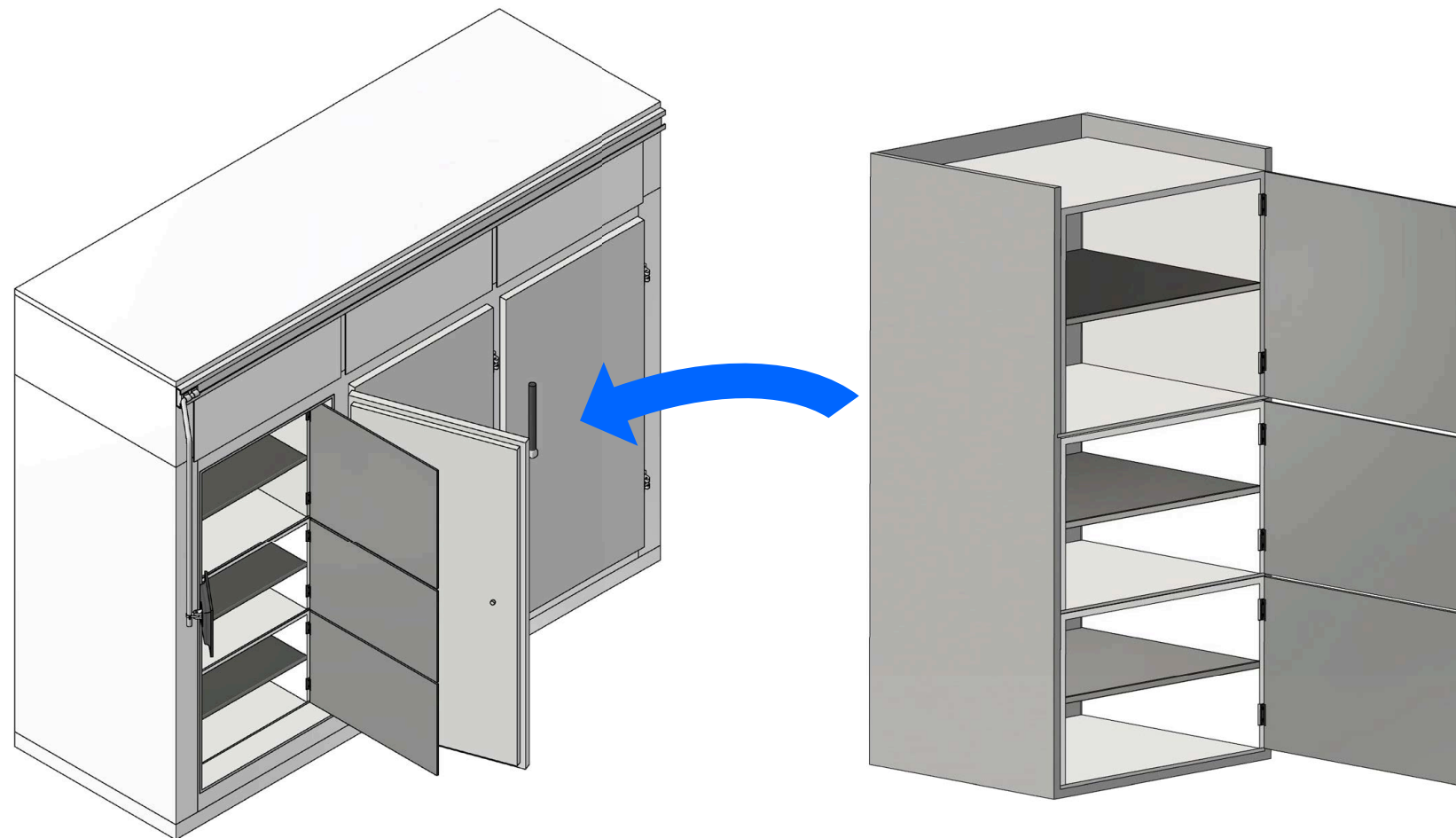
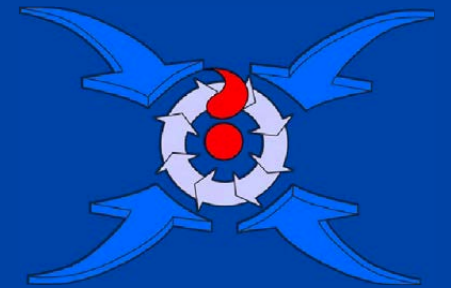

A second model comes with only shelves, which is a simple storage solution at every height.

This can be divided into multiple sections with separate doors.

BOS BOS MS - Multifunctional-System

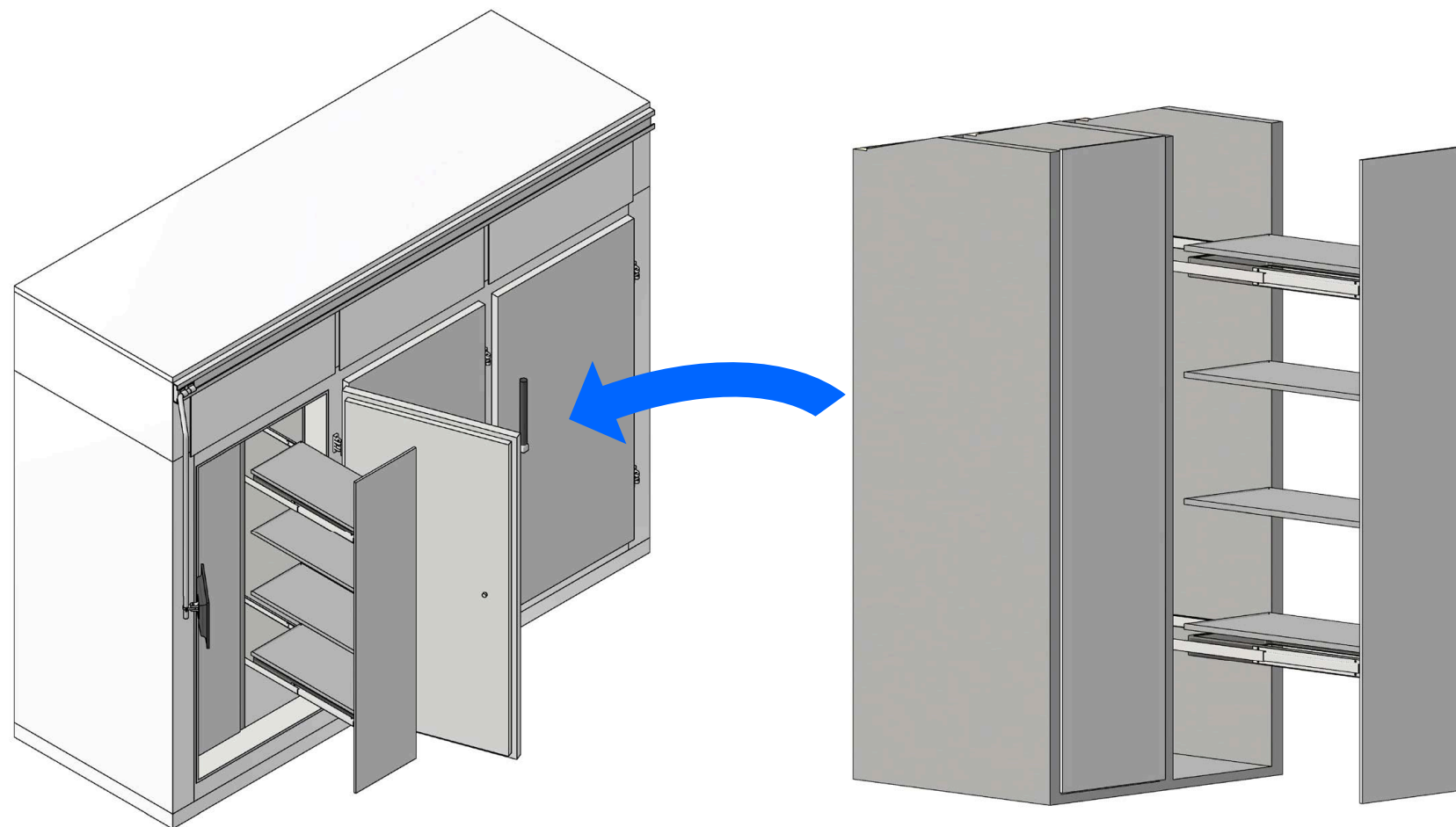
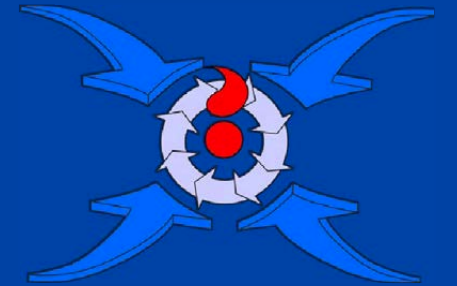

Another version is equipped with drawer like shelves that can be pulled out and stocked from the sides.

BOS BOS MS - Multifunctional-System

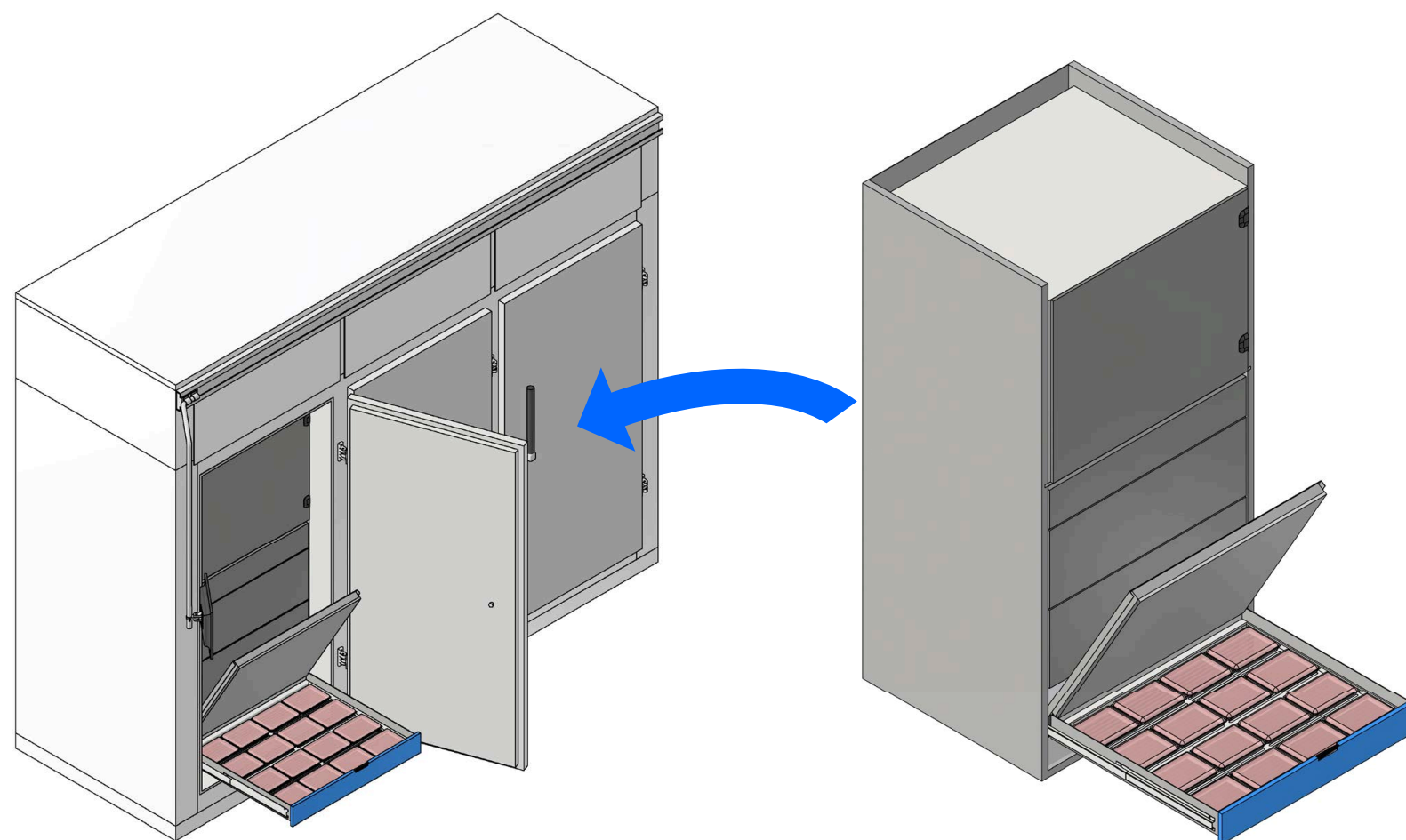
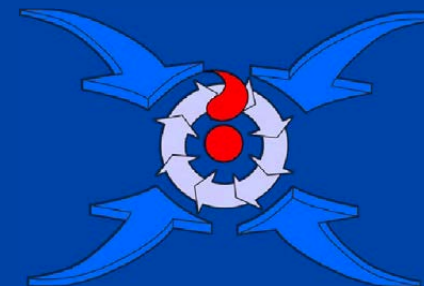

The possibilities don't end with simple storage solutions. The BOS MS can be outfitted with a freezing drawer that is equipped with its own heat exchanging system and can freeze many type of products, for example Bags of blood plasma.

BOS BOS MS - Multifunctional-System

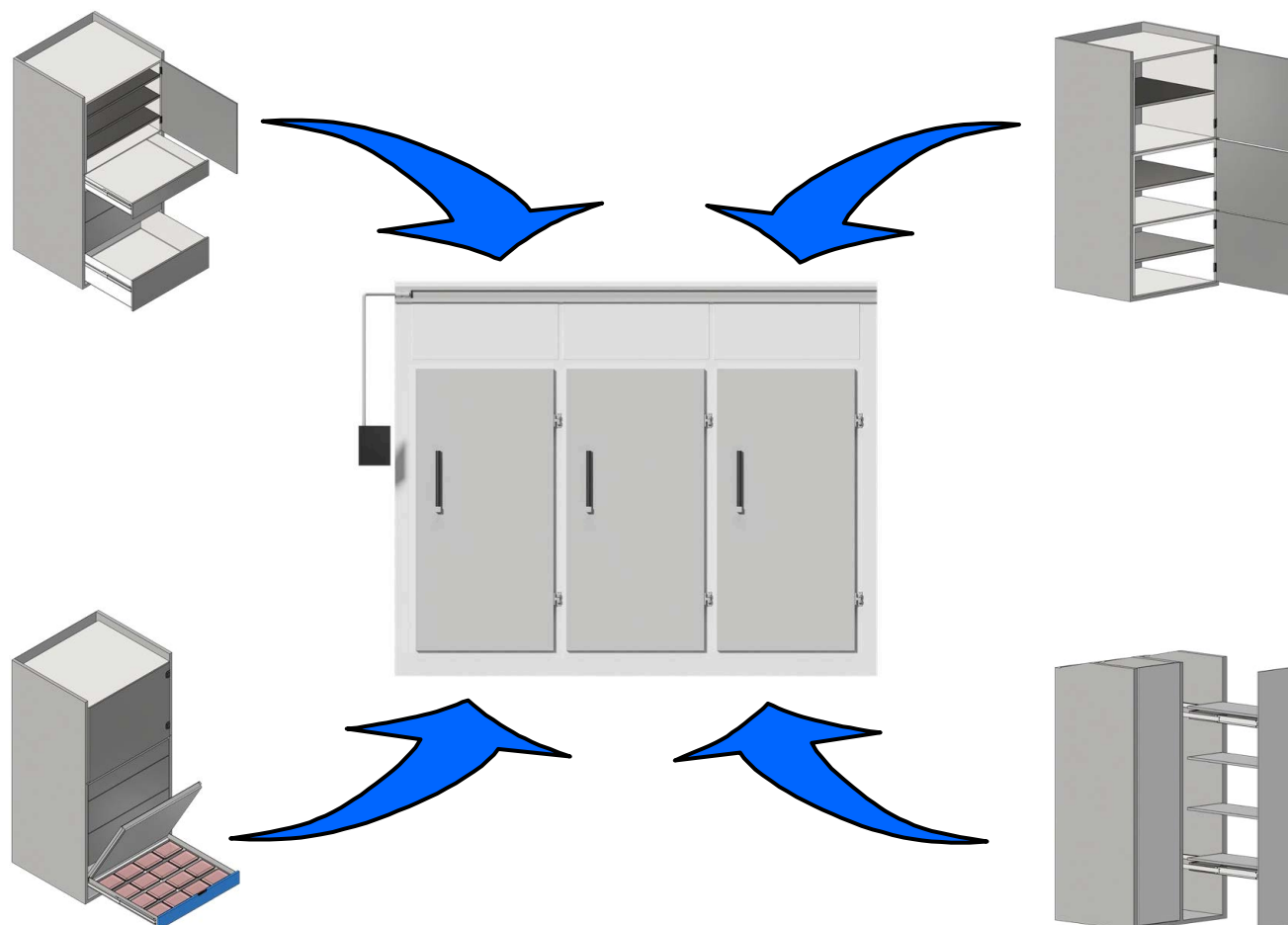
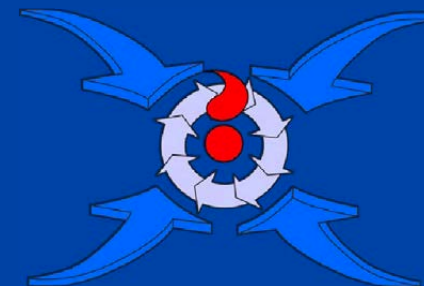

The BOS MS is created to be a versatile tool for every professional that needs to freeze, store and manage a wide selection of products that need to be kept at low temperatures.

The storage inserts can be chosen freely and offer the benefits of every solution.

The LN2 consumption depends on the system size (1m³, 5m³ and more) as well as the temperature and other factors.
This can mean a range of 20 kg -200kg and more per day, static consumption.

Consumption can be more than halved with NNC cascade use.

Price for LN2, depending on purchase at least 12 to 15 cents / kg

BOS 800 Semi-automatic

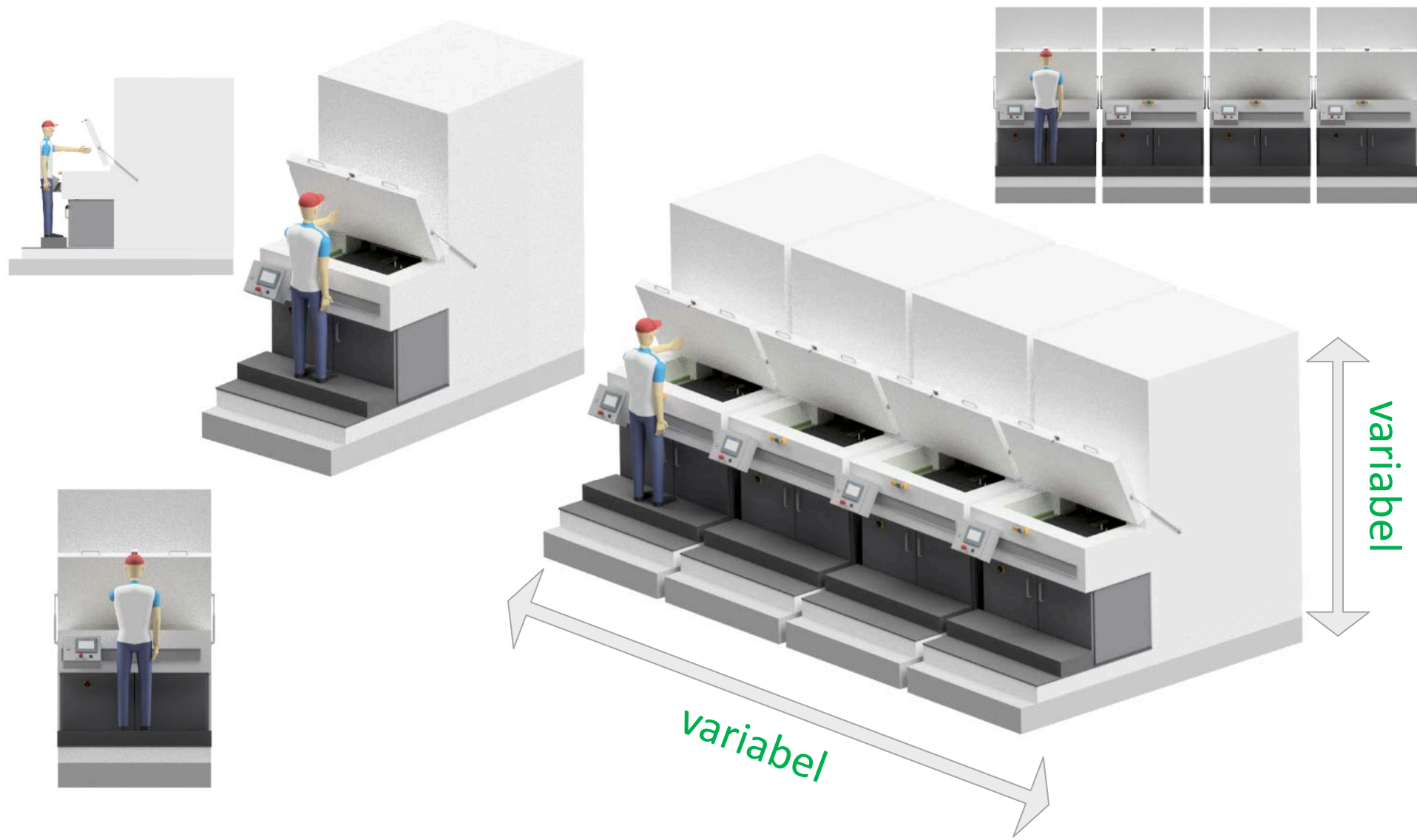
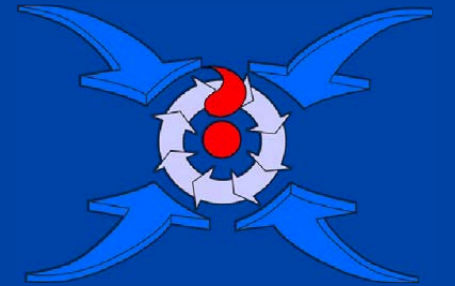

BOS 800 Semi-automatic

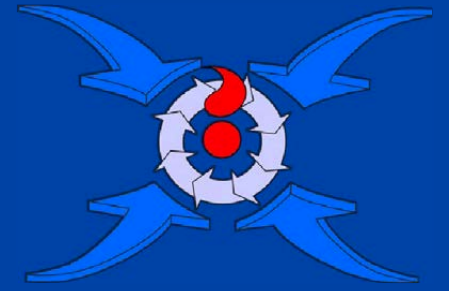

The **NNC BOS 800 / Semi-automatic System** is a semi-automated storage system for materials that are existentially dependent on orderly handling in secured ambient temperatures. The finely adjustable temperatures are between +10°C and -130 °C, and are kept in the range +/- 1K.

The main storage is a compact block, which is organized and very compressed and in combination with NNC's own cooling system, ensures a very constant, secured temperature.

The lifting/sliding device ensures targeted and secure access to the stored products.

Dispensing and operation takes place in a temperature-controlled working drawer. The tray with a defined number of racks (flexibly deployable) is inserted and/or extracted into this drawer. The drawer is the secure working area for manual processing of the samples. Ergonomically optimized and appropriate for the application.

The systems are to be operated as customer-specific systems, as well as in a growing system arrangement. Each system has its own control system. The controllers and their alarms can be merged in order to provide the house alarm system with targeted information. Each system has 3 temperature sensors. 2 sensors for visualizing the temperatures, one sensor for regulating the temperatures.

The systems have NNC specific refrigeration technology, consisting of special cooling plates, both in the primary and secondary cooling areas. The excess Energy can be used for secondary systems. With this arrangement, almost 100% of the supplied energy can be used.

LN2 is about 78% part of the air we breathe. The air is liquefied, used and released again, CO2 neutral when produced from renewable energy.

An attached system sample management system with corresponding connection to existing house systems can also be provided as an option. This has to be individually coordinated.

BOS 800 Semi-automatic

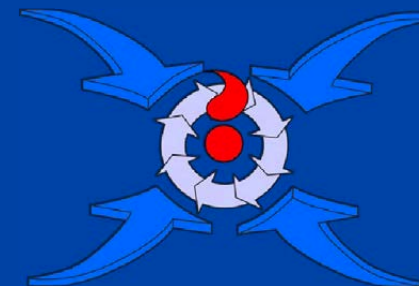

Standard Rack
ca. 127 x 85mm x 60mm
with all known versions 24, 48, 96 racks
and the associated sample tubes from many
manufacturers
Also possible to use microtiter plates

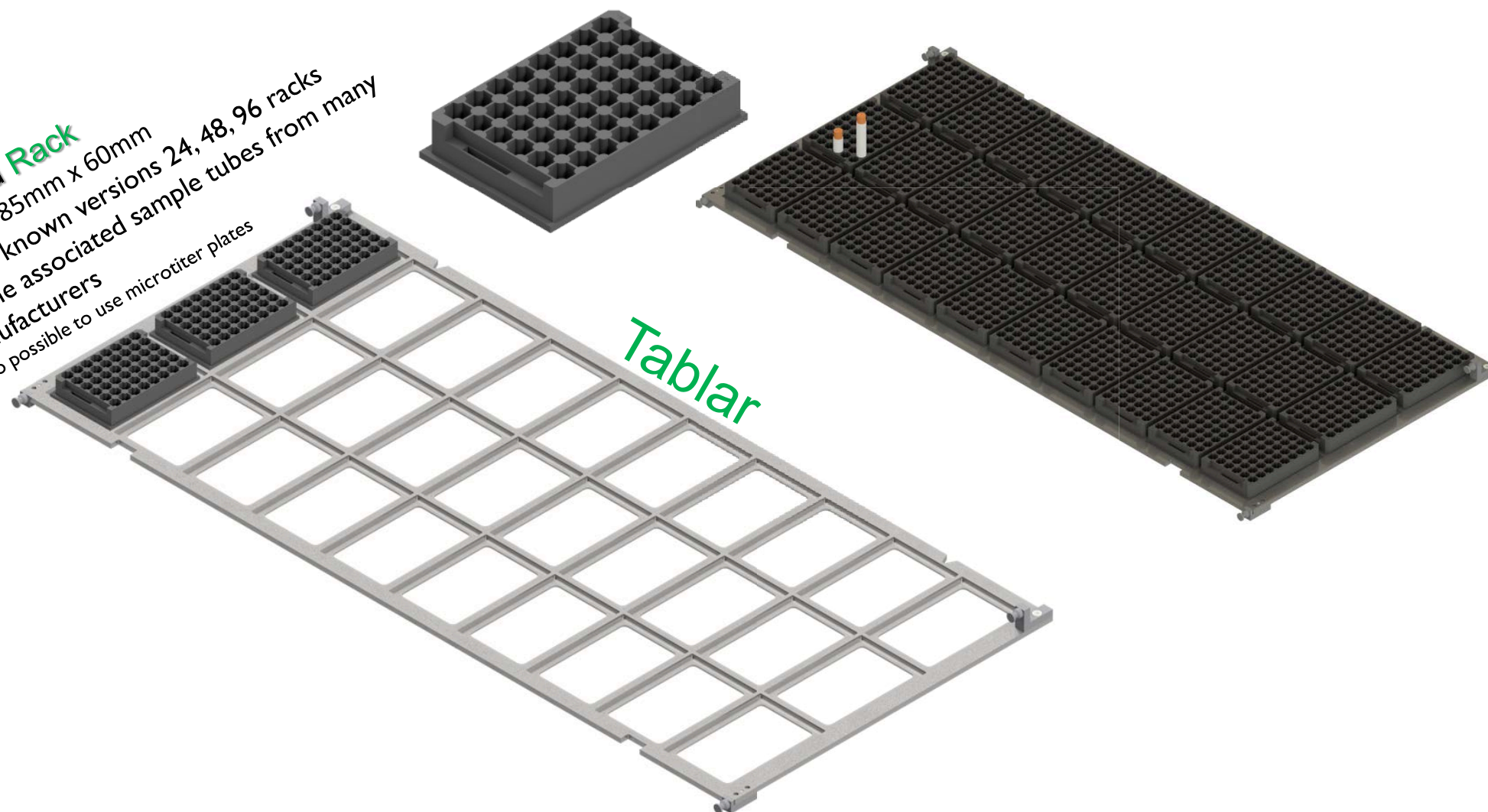

BOS 800 Semi-automatic

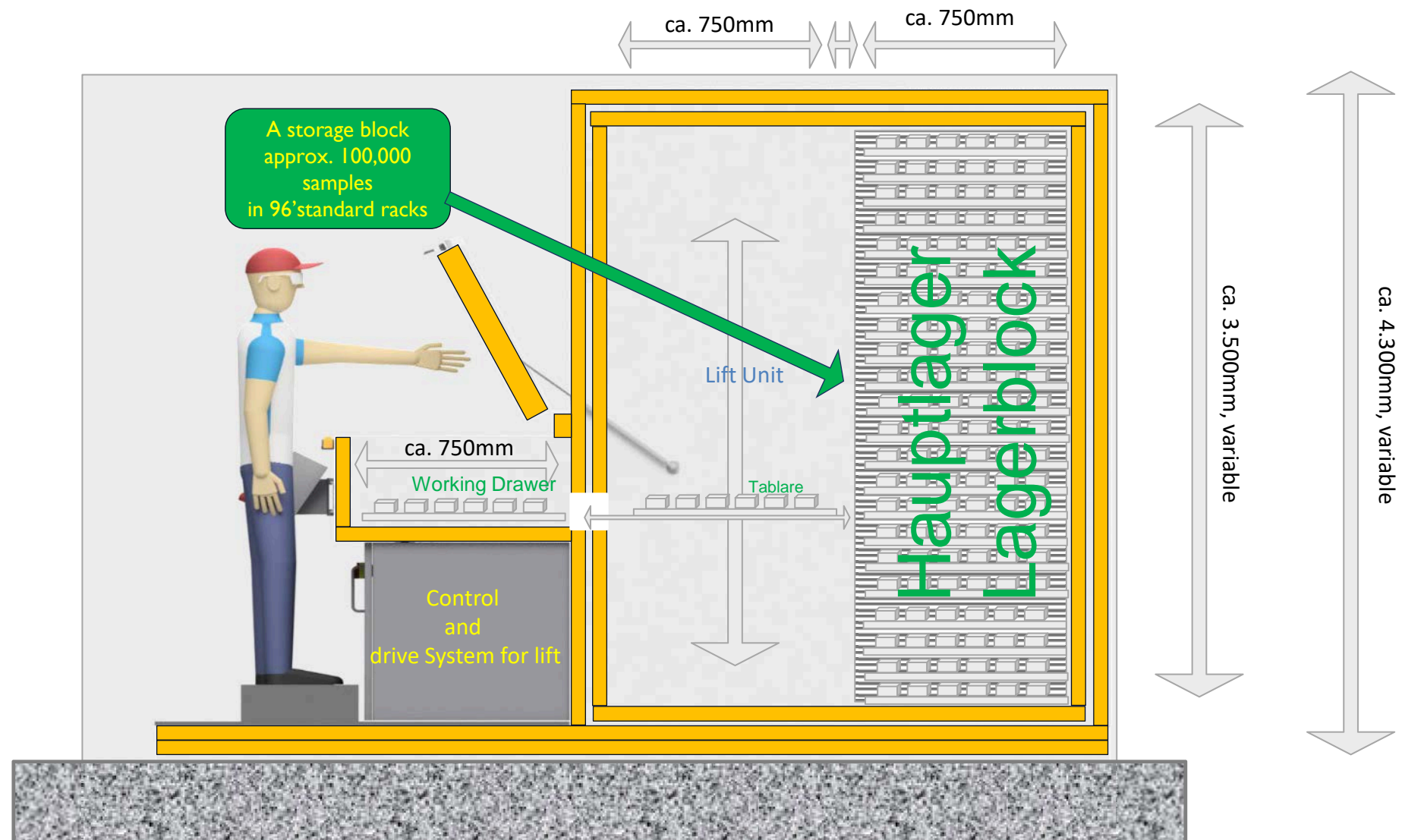
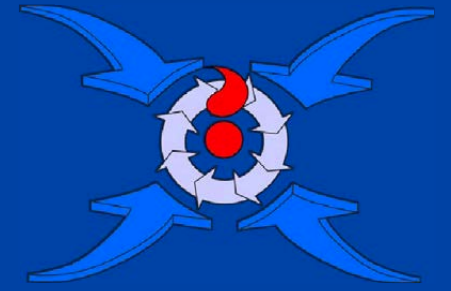

BOS „AKELOP“ Fully Automated (In Development)

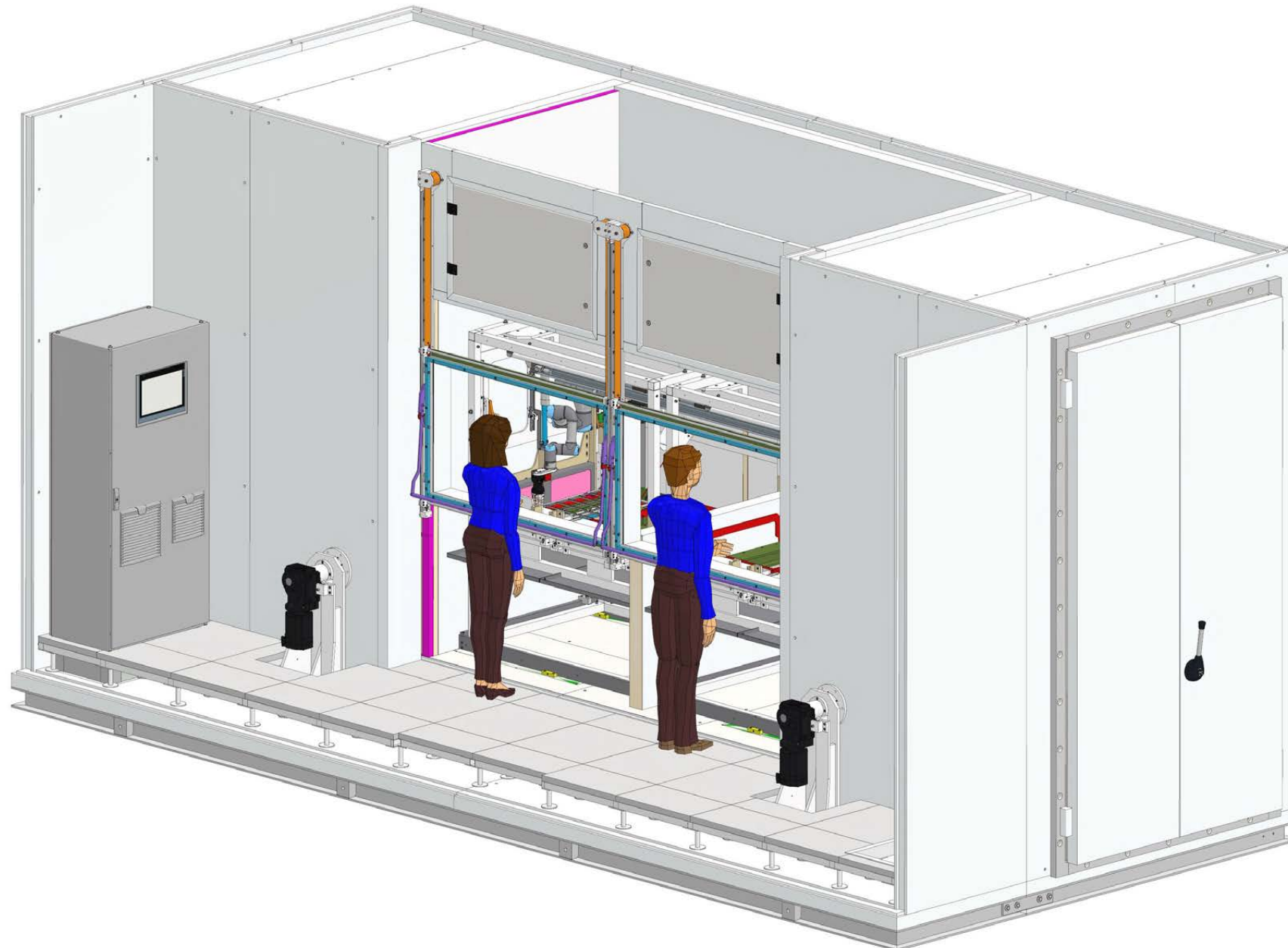
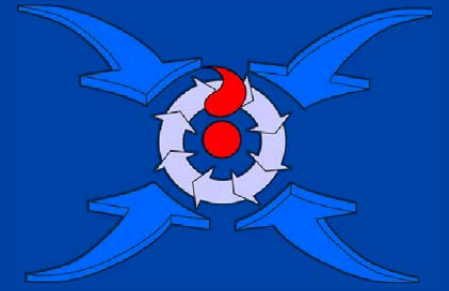

BOS „AKELOP“ Fully Automated (In Development)

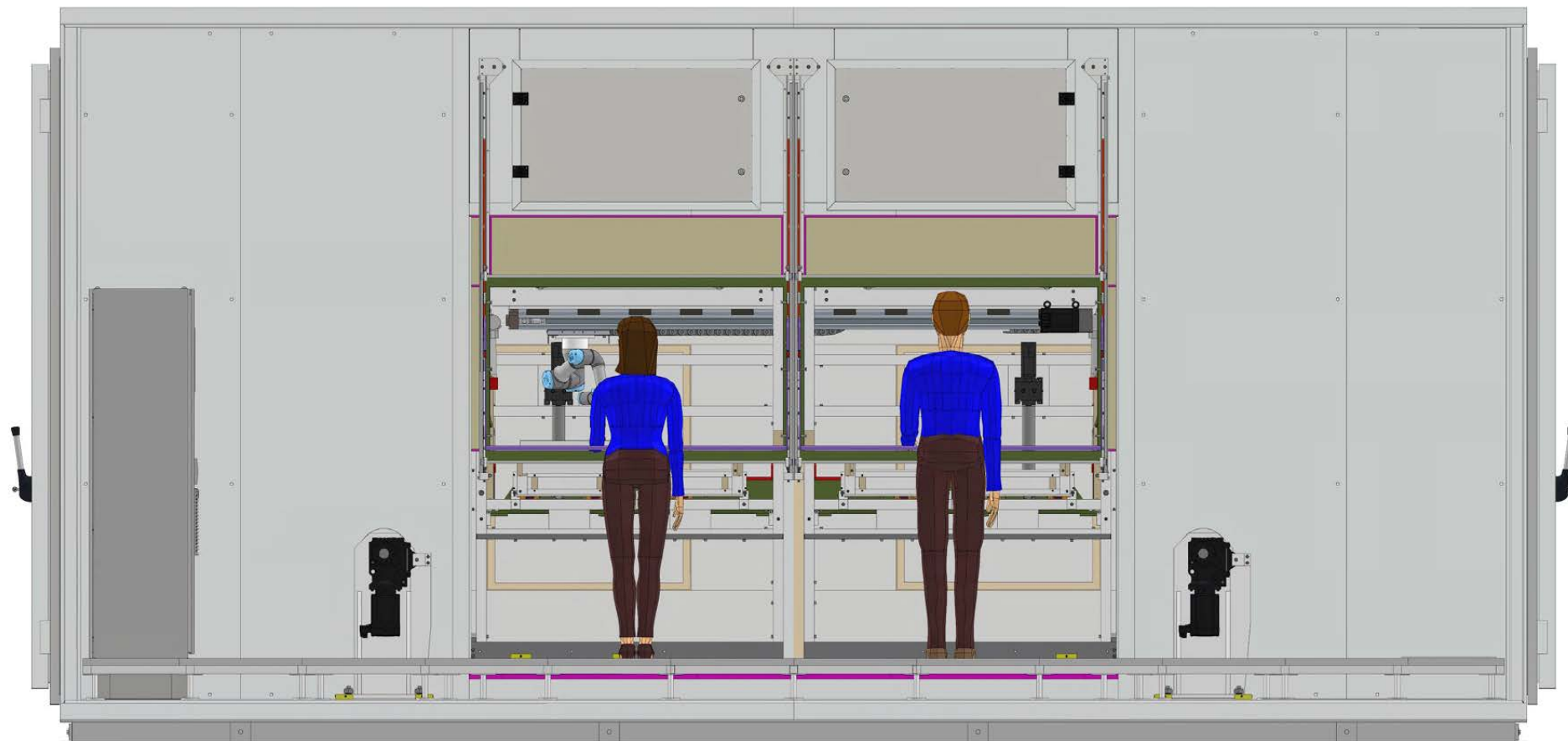
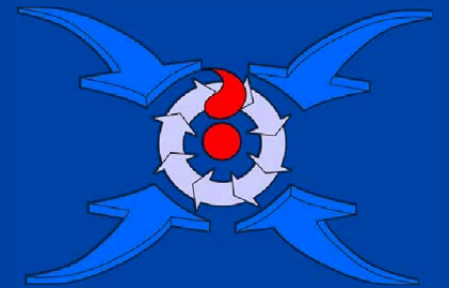

BOS „AKELOP“ Fully Automated (In Development)

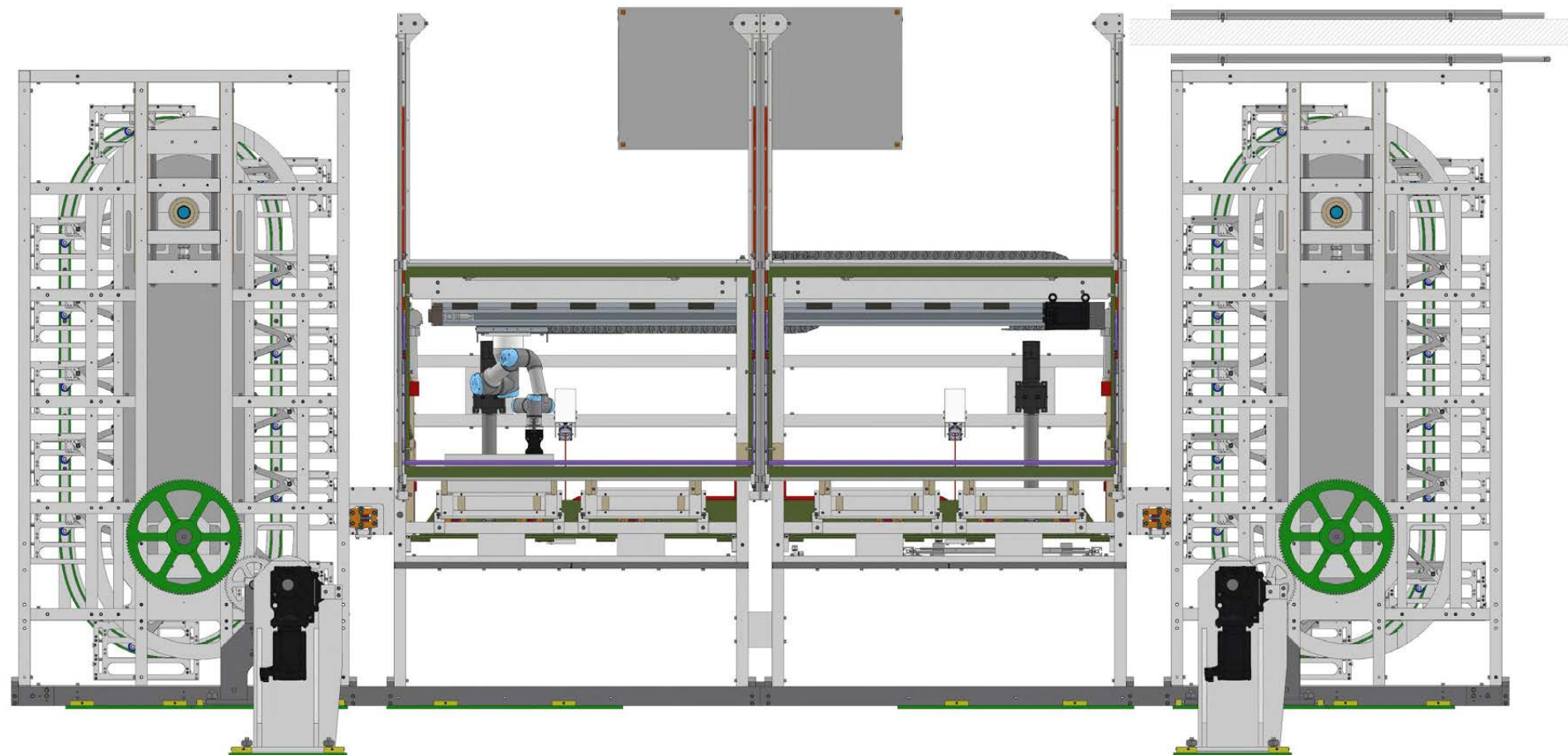
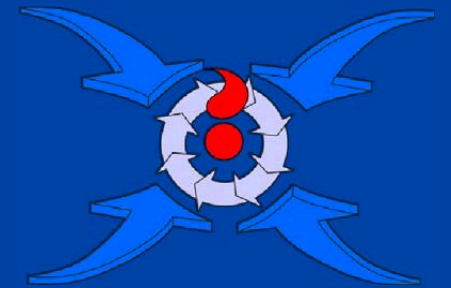

BOS „AKELOP“ Fully Automated (In Development)

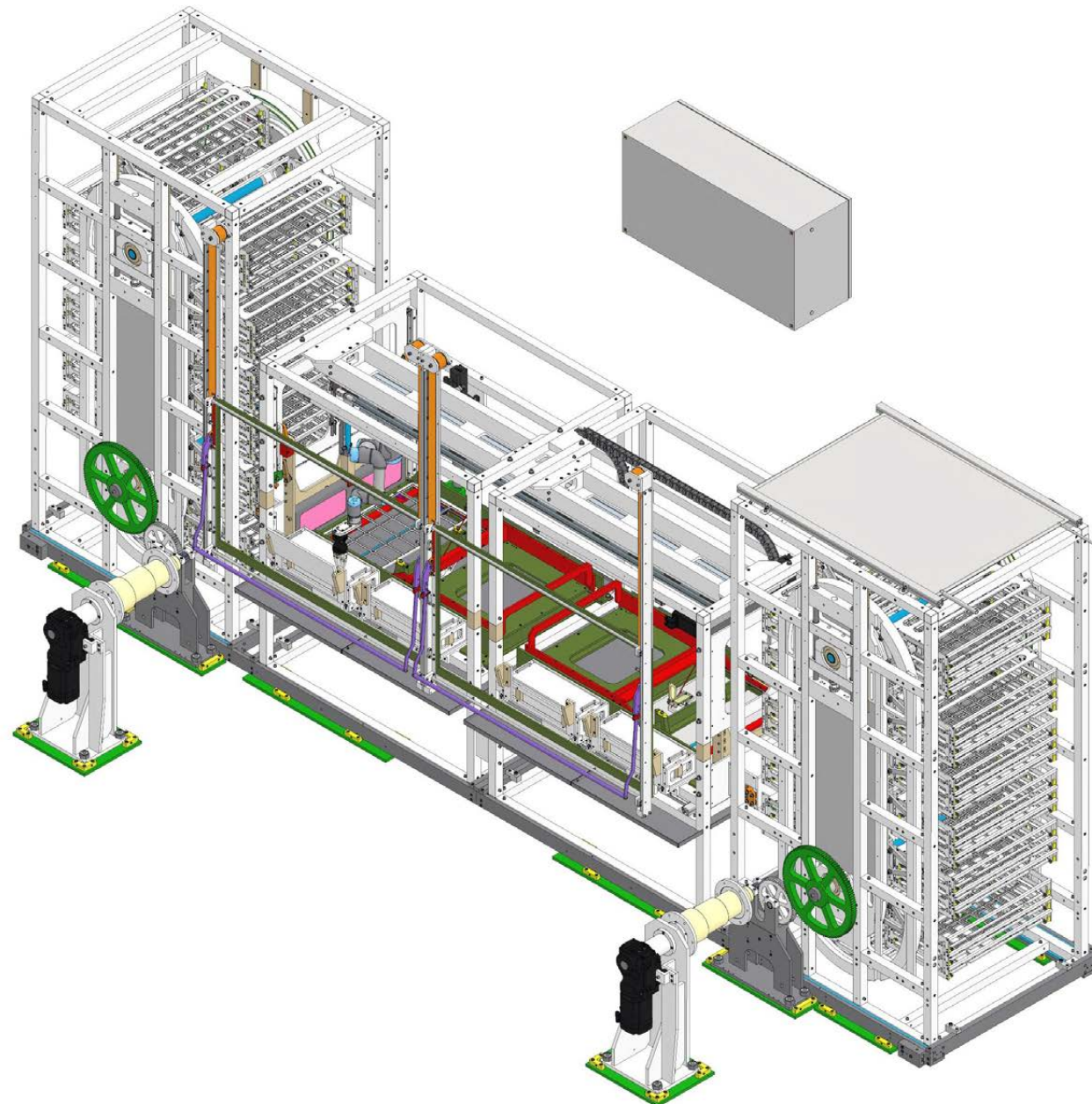
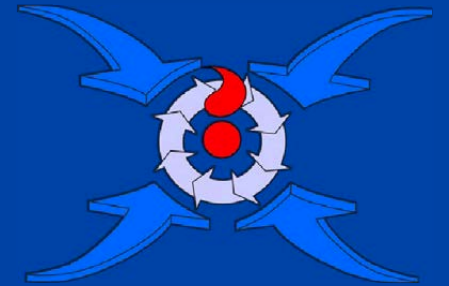

BOS Chest system

The traditional chest with modern cooling

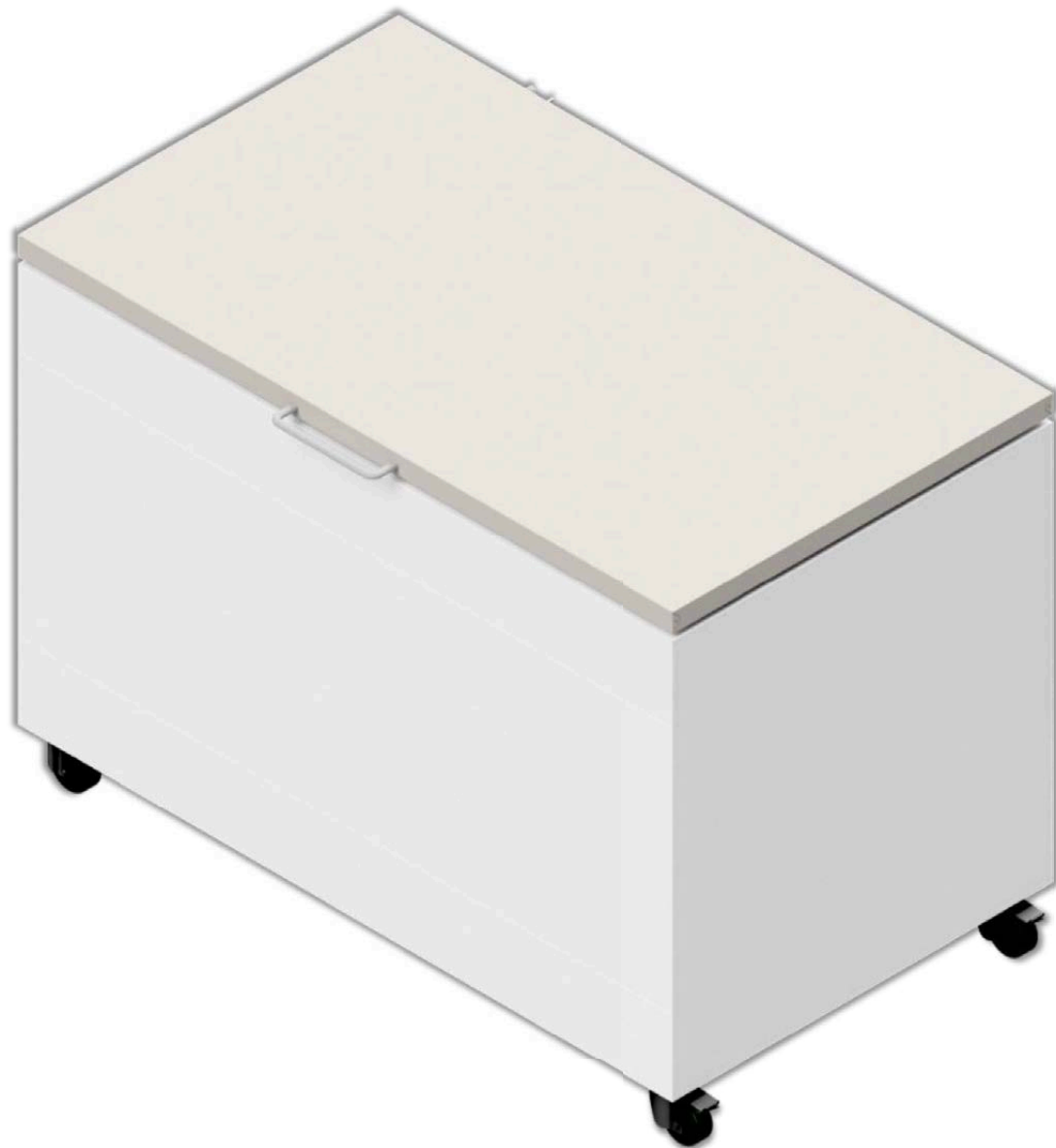
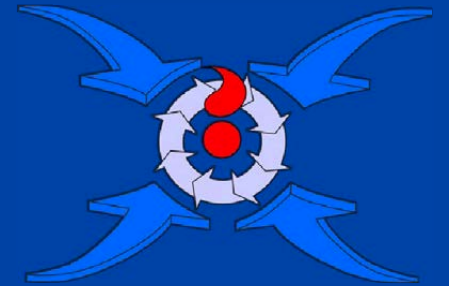

BOS Chest system

The traditional chest with modern cooling

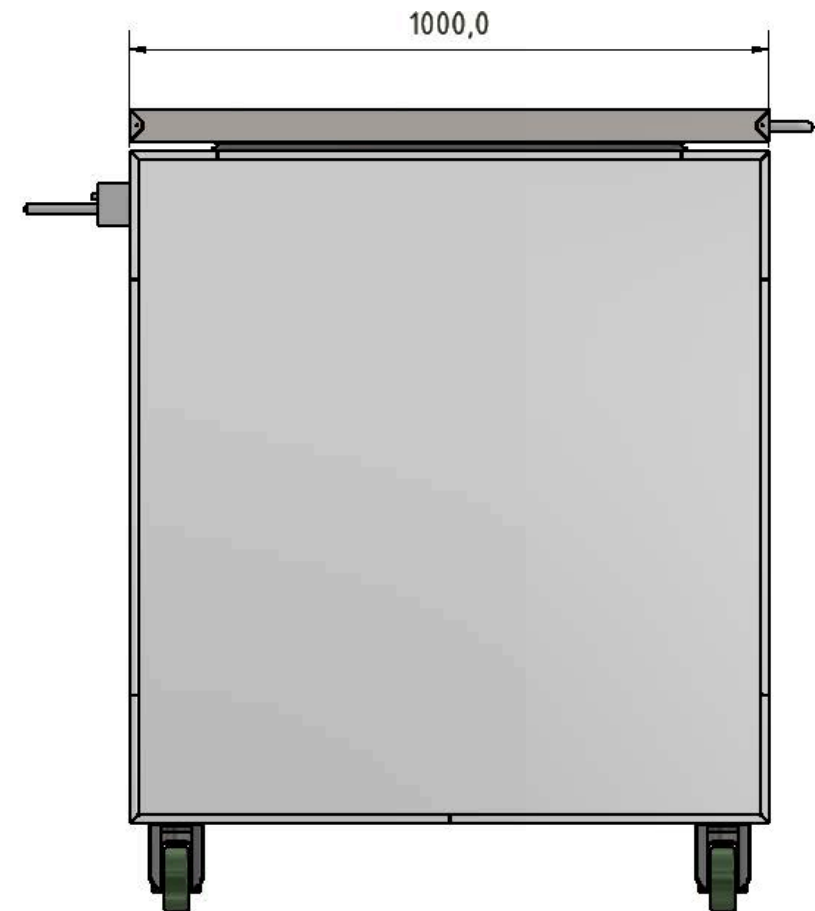
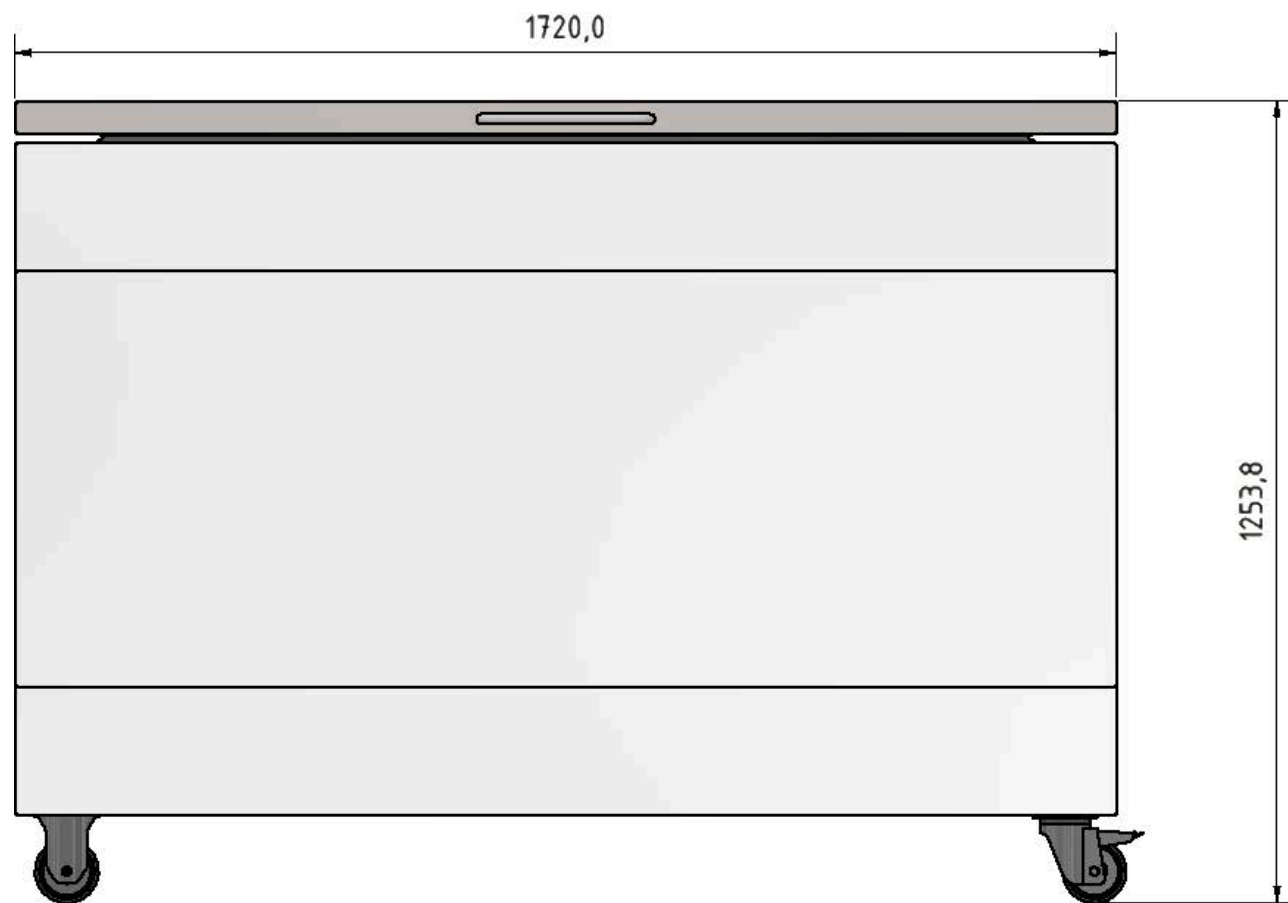
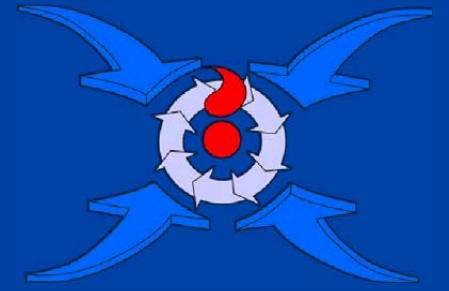



References

OUR CUSTOMERS

Am Kleinbahnhof 18-30 – 25746 Heide (DE)

www.nnc-lin.com
info@nnc-lin.com – +49(0)481 81787763

References: Universities in Düsseldorf (DE), Köln (DE), Freiburg (DE) Drum systems with auto-access

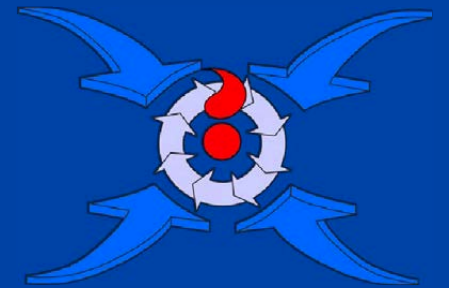

Drum System up to -40°C

Product identification via PDA

Workstation with status and storage capacity overview

References: Blood donation Zurich (CHE) Cabinet system

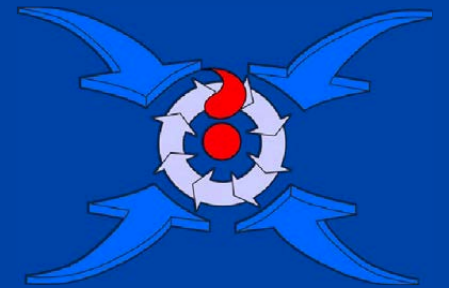

Cabinet System up to -40°C

Product identification via Display

References: IDT Biologika Dessau-Roßlau (DE) Pharmaceutical Storage

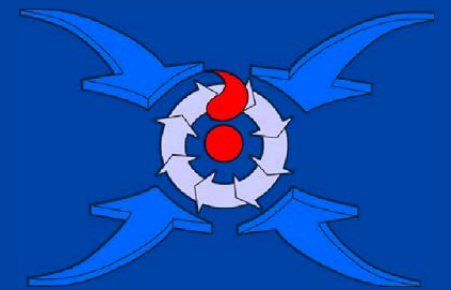

Open Plan System up to -80°C

Storage, Interim Storage, Defrosting

References: Vetter Pharma Ravensburg (DE) Pharmaceutical Storage

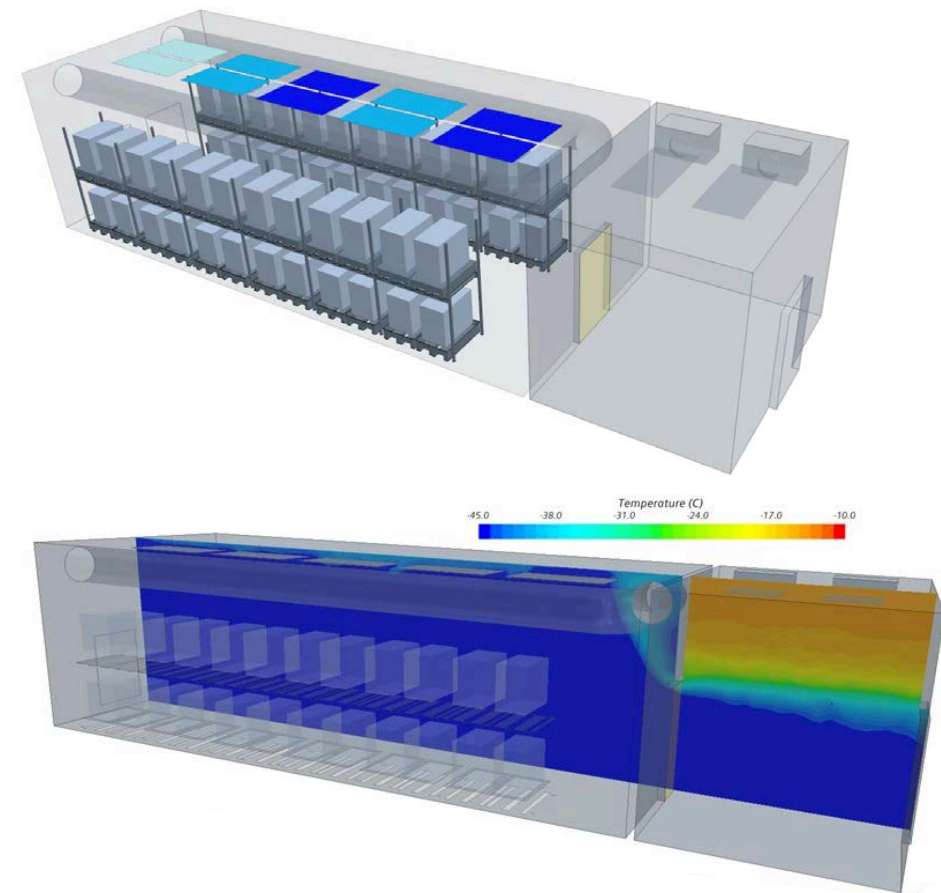
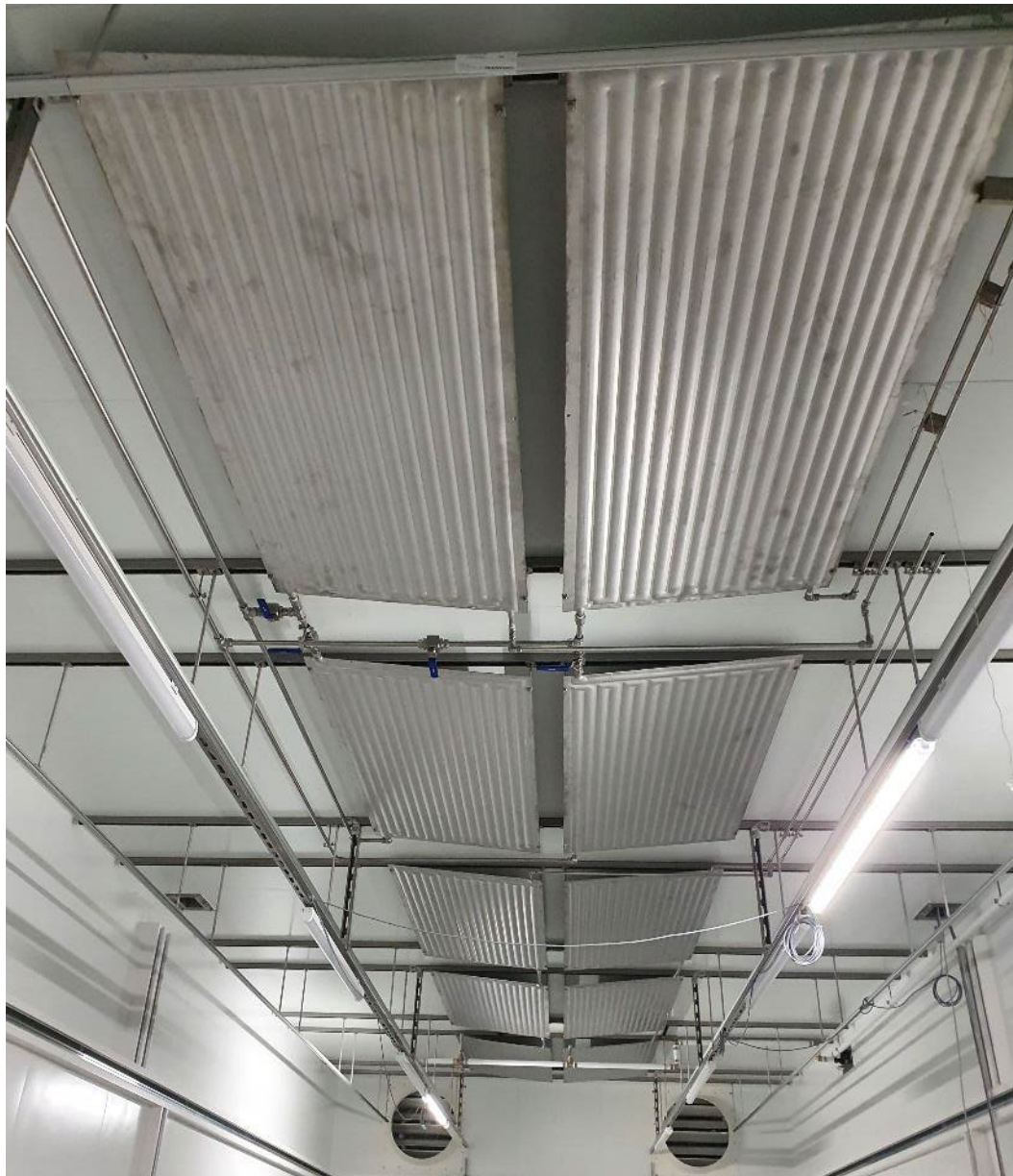
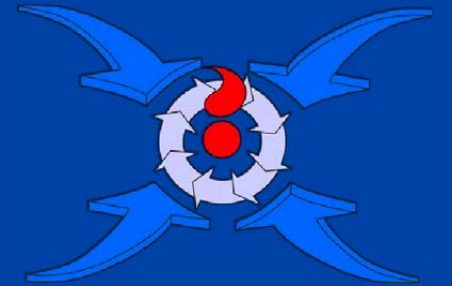

2 Room System up to -40°C

Storage with transit zone

Active Cooling with Backup cooling

References: Haema, Leipzig(DE) Production and storage of blood products

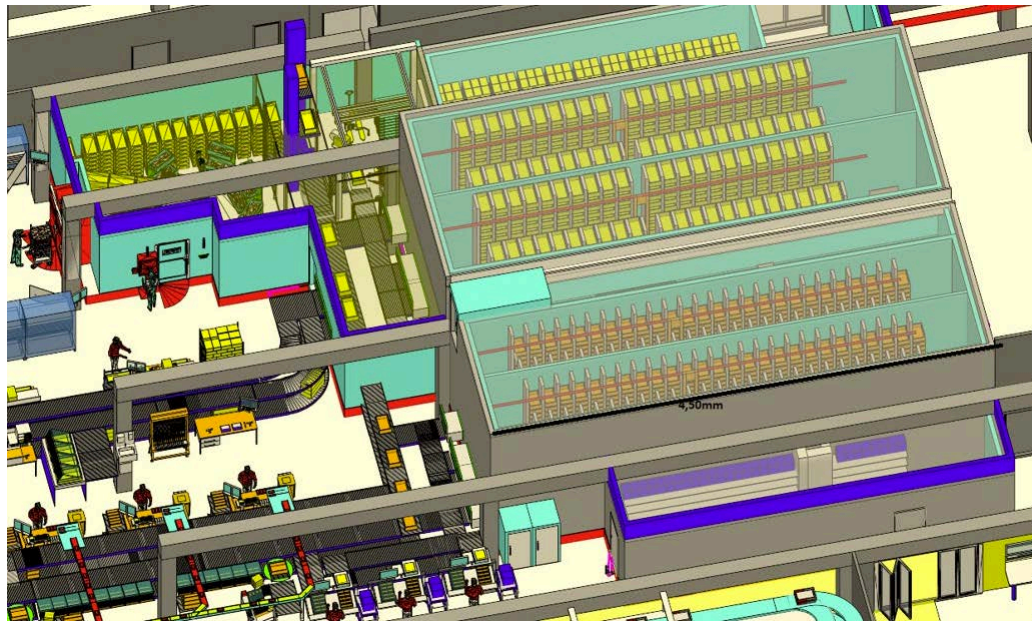
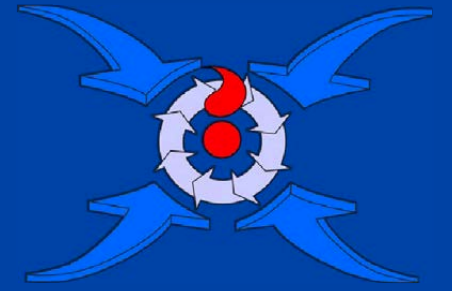

Automated cold rooms
between +4 and -40°C

Applied
Cascade cooling

of the NNC Group

with +4-6°
Chilled water generation from the refrigeration, the exhaust gas flow, to the Centrifuge Refrigeration as well as cooling of the IT server room

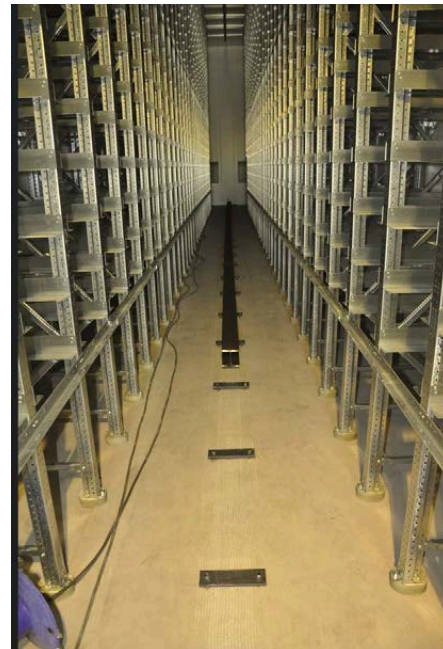

References:

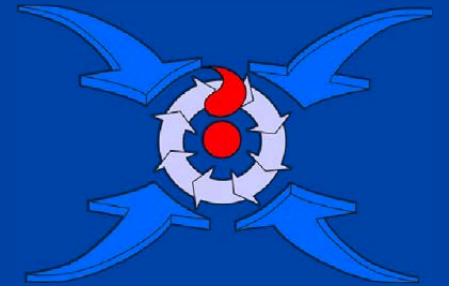

Universities

Düsseldorf

Köln

Freiburg

Hamburg

and more

Red Cross

Switzerland

Poland

Germany

Niederlande

and more

Industrie

Haema Leipzig /

Vetter Pharm. /

IDT Pharm. /

Bayer AG

and more

Contact:

NNC-LIN MS GmbH

Research & Development / Distribution

Am Kleinbahnhof 18-30 - 25746 Heide

Administration

Uhlenstroot 3 - 25797 Wöhrden

Phone: +49 (0) 481 817 877 65

+49 (0) 4839 865 99 82

Fax: +49 (0) 4839 865 99 81

Email: info@nnc-lin.com

www.nnc-lin.com

THANK YOU

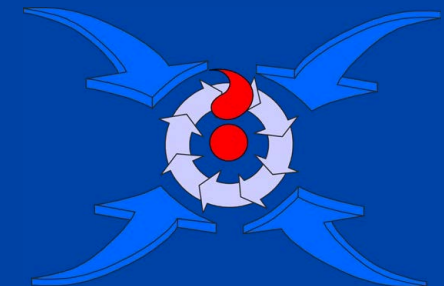

NNC-LIN MS GmbH



NNC-Group